

tapflo®

SUBMERSIBLE PUMPS

2022 | 1



» All about your flow®

www.tapflo.com

» All about your flow™

We began our journey in 1980 in Kungälv, a small town on the Swedish west coast, as a family company with an ambition to one day become a global player on the pump market.

Since the foundation, we have taken pride in delivering a wealth of knowledge and passion for pumps to the industry, whilst supplying a wide range of premium products for various industrial applications.

Over the years, the company has developed into a global Tapflo Group with branches and distributors present in nearly every region of the world.

One thing did not change - we are still a family company.

Our solutions are designed and manufactured in Europe and distributed globally to offer the best service and flow solutions to our customers for a variety of applications.

Our values, Commitment, Quality and Simplicity are reflected both in our product and business approach.



For fast and flexible service and high-quality products readily available worldwide, choose Tapflo.

Quality commitment

At Tapflo we are simply committed to quality. As a result, our production standards, as well as products quality, comply with various globally recognised certification and quality control standards. The Tapflo manufacturing process is certified according to ISO 9001:2015, confirming that our processes are appropriate, effective, customer-focused and continuously improved.



Tapflo values

Our culture is concluded in Our values

Commitment

We are different from our competitors because of our willingness to exceed the customers' expectations, move fast and be flexible. Our culture is based on the spirit of togetherness, enthusiasm and integrity. We come from all over the world but we share the same values and we respect each other. We are committed.

Quality

We understand that the quality in our work is never better than the weakest link, that's why we focus on every small detail. We share a common passion for continuously finding more efficient and effective ways to provide value to our customers. As a manufacturer we have control of the complete process both in terms of our products and the way we operate internally. That is why we manufacture the highest quality pumps in our segment.

Simplicity

We have a saying, "Simple is art" which means we try to find smooth and uncomplicated solutions in everything. By keeping it simple we can focus on the essential, like designing uncomplicated pumps with few components. For us it is a key to success; strive to simplify what is complex.

Submersible pumps

One solution for all your submersible pump needs

Tapflo submersible pumps are designed for an extensive range of applications. We offer pumps for drainage of flat surfaces, sewages, dewatering of spring, rain and ground water as well as slurries and sludges containing particles. All our submersible pumps provide the performance, reliability and ease of use you need when pumping fluids mainly consisting of water.



Features & Benefits

- ✓ **Effective motor cooling**
Discharge channel is part of the motor housing and effectively cools motor
- ✓ **Over heating protection**
Pump stops at too high temperatures, automatically cools down, then starts again
- ✓ **Automatic level control**
Optional float switch and level sensor that controls operation based on water level
- ✓ **Protection against reverse phase**
Ensuring correct impeller rotation
- ✓ **Models with agitator**
Minimises clogging for free pump passage
- ✓ **Rigid construction**
Pump body and motor made in robust materials

Applications



Drainage pumps

Pumps for complete drainage of flat surfaces where sump is not available. For example rooftops, parking lots, facilities and cellars

SG series

SG has a smart design bottom plate that enables the pump to operate and drain down to 1 mm water level. The pump is equipped with a swing valve that prevents reverse flow from discharge hose when the pump is shut-off. A rubber stand protects the floor and ground surfaces from any scratches.

Water cooling route to the top outlet, allows the pump to operate for extended periods while pumping small amounts of water.

The discharge direction can be mounted either vertical or inclined, which prevents folding or bending of the discharge hose.

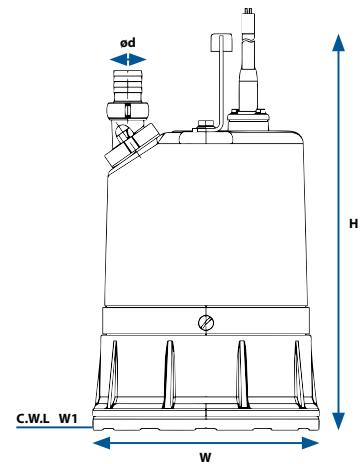

Fast facts

Capacity:	14 m ³ /h
Head:	11.5 m
Power:	0.48 kW, single-phase 230 V ± 10 %, 50 Hz
Insulation class:	F
Protection class:	IP 68
Outlet:	25 mm
Water temperature:	Up to 40 °C
Max water depth:	10 m
Cable length:	8 m

Technical data

Model (50 Hz)	Height (H)	Width (W)	Weight (net)	Outlet (ød)	Continuous running water level (W1)
	mm	mm	Kg	mm	mm
SG2-04	358	205	12.6	25	1

Model (50 Hz)	Motor power	Voltage	Rated Capacity		Rated head	Max capacity		Max head	Impeller Passage	Max depth
	kW	V	m ³ /h	l/min	m	m ³ /h	l/min	m	mm	m
SG2-04	0.48	230	7	116	7	13	216	11.5	6	10

Performance curves - 50 Hz, 2850 rpm

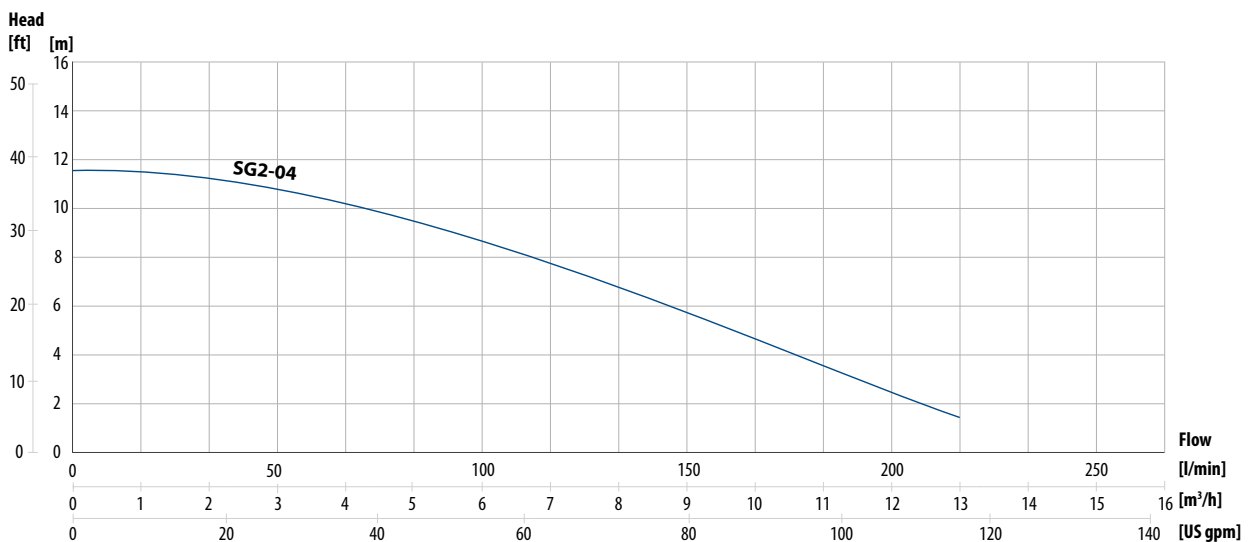

Sewage pumps

Suitable for light sewages, cellars, sumps, dirty water and effluents

SPT series

Tapflo SPT is made from stainless steel and thermoplastic. This makes the pump not only light in weight, but also corrosion resistant. The pump is equipped with a vortex impeller and large free passage clearance allowing it to readily dispose liquid containing suspended soft solids and fibrous materials.

SPT has a level control float switch that saves energy and makes it operator free as well as double connections, hose and BSP.



Fast facts

Capacity:	Up to 22.2 m ³ /h
Head:	Up to 13.5 m
Power:	0.25-0.75 kW, single-phase 220 V ± 10 %, 50 Hz
Insulation class:	F
Protection class:	IP 68
Outlet:	50 mm/ 2"
Water temperature:	Up to 40 °C
Max water depth:	10 m
Cable length:	8 m

Technical data

Model (50 Hz)	Height (H)	Width (W)	Weight (net)	Hose outlet (ød)	BSP thread (ød)	Continuous running water level (W1)	Lowest running water level (W2)
	mm	mm	Kg	mm	in	mm	mm
SPT2F-04P	370	234	10	50	2	270	110
SPT2F-07P	400	234	13	50	2	300	110

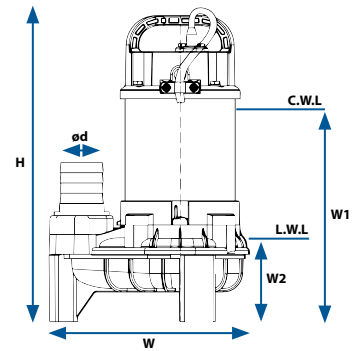

Model (50 Hz)	Level control	Motor power	Voltage	Rated Capacity		Rated head	Max capacity		Max head	Impeller Passage	Max depth
		kW	V	m ³ /h	l/min	m	m ³ /h	l/min	m	mm	m
SPT2F-04P	Float switch	0.4	220	9	150	6	16.8	280	9.5	35	10
SPT2F-07P	Float switch	0.75	220	12	200	9	22.2	370	13.5	35	10

Performance curves - 50 Hz, 2850 rpm

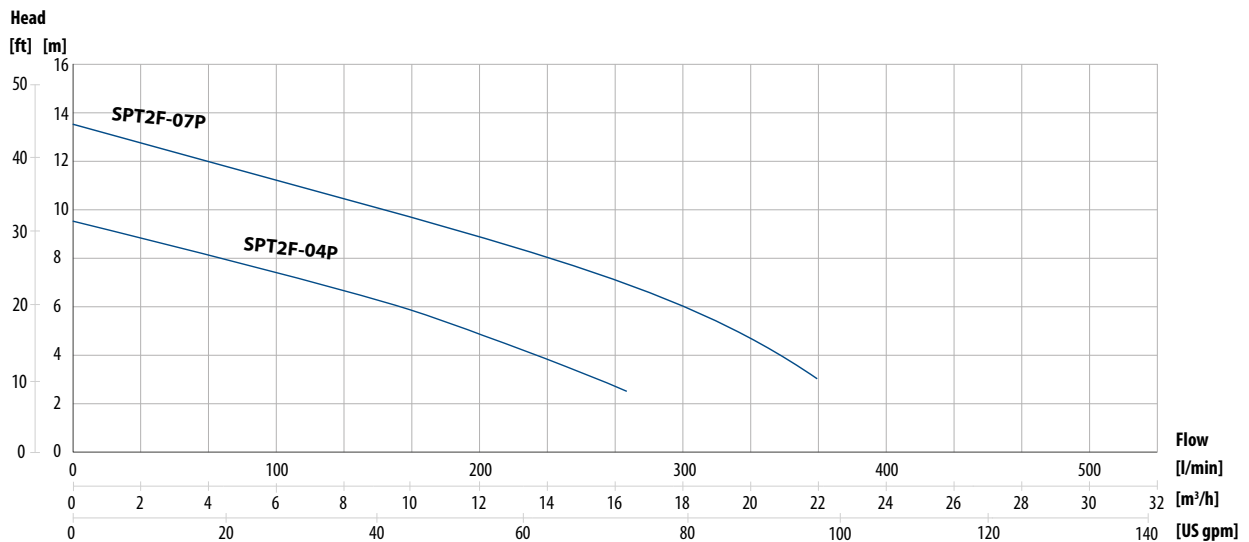

Dewatering pumps

Dewatering pumps for spring water, rainwater, groundwater and sand carrying water that are widely used in mines and quarries, construction, tunneling, industry processing and hire fleets

SK series

Pump body is made of rigid stainless steel, that makes it light and portable, and cast iron, for long lasting durability. A semi-open impeller made of high chrome alloy match with wearable plate (ductile iron) achieves superior durability.

The discharge channel cast is part of the motor housing that effectively cools motor and motor is hermetically sealed equipped built-in thermal protection.

Most models has a level control float switch that saves energy and makes it operator free as well as double connections, hose and BSP.

SK2(F)-15(P) includes dual position outlet port to enable the user to position the discharge hose in either horizontal or vertical direction to avoid hose folding or bending. The model also has a greatly increased maximum submersion depth due to a mechanical seal that is resistant to high pressure.



Fast facts

Capacity:	Up to 30 m ³ /h
Head:	Up to 21 m
Power:	0.25-1.5 kW, single-phase 220 V ± 10 %, 50 Hz/ 1.5 kW, three-phase 400 V ± 10 %, 50 Hz
Insulation class:	F
Protection class:	IP 68
Outlet:	50 mm/ 2"
Water temperature:	Up to 40 °C
Max water depth:	25 m
Cable length:	8 m

Dimensions

Model (50 Hz)	Height (H)	Width (W)	Weight (net)	Outlet (ød)	BSP thread (ød)	Continuous running water level (W1)
	mm	mm	Kg	mm	in	mm
SK2F-02P	345	184	14	50	2	50
SK2F-07P	365	184	17	50	2	50
SK2F-15P	582	240	37	50	2	87
SK2-15	563	240	37	50	-	87

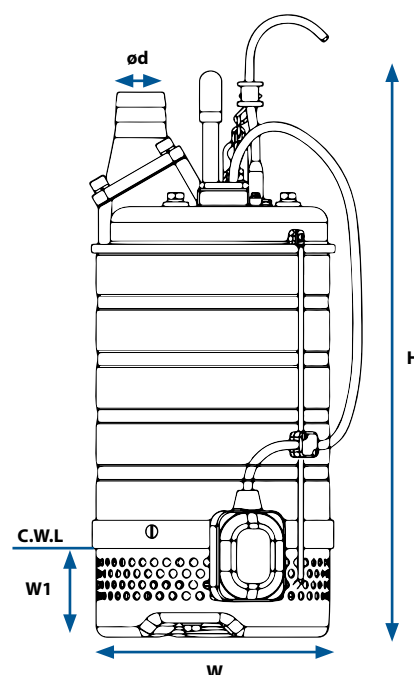

Technical data

Model (50 Hz)	Level control	Motor power kW	Voltage V	Rated Capacity		Rated head m	Max capacity		Max head m	Impeller Passage mm	Max depth m
				m ³ /h	l/min		m ³ /h	l/min			
SK2F-02P	Float switch	0.25	220	6	100	7	12	200	8	6	10
SK2F-07P	Float switch	0.75	220	10	166	12	19.5	325	15	6	10
SK2F-15P	Float switch	1.5	220	15	250	15	30	500	21	8.5	25
SK2-15	-	1.5	400	15	250	15	30	500	21	8.5	25

Performance curves - 50 Hz, 2850 rpm

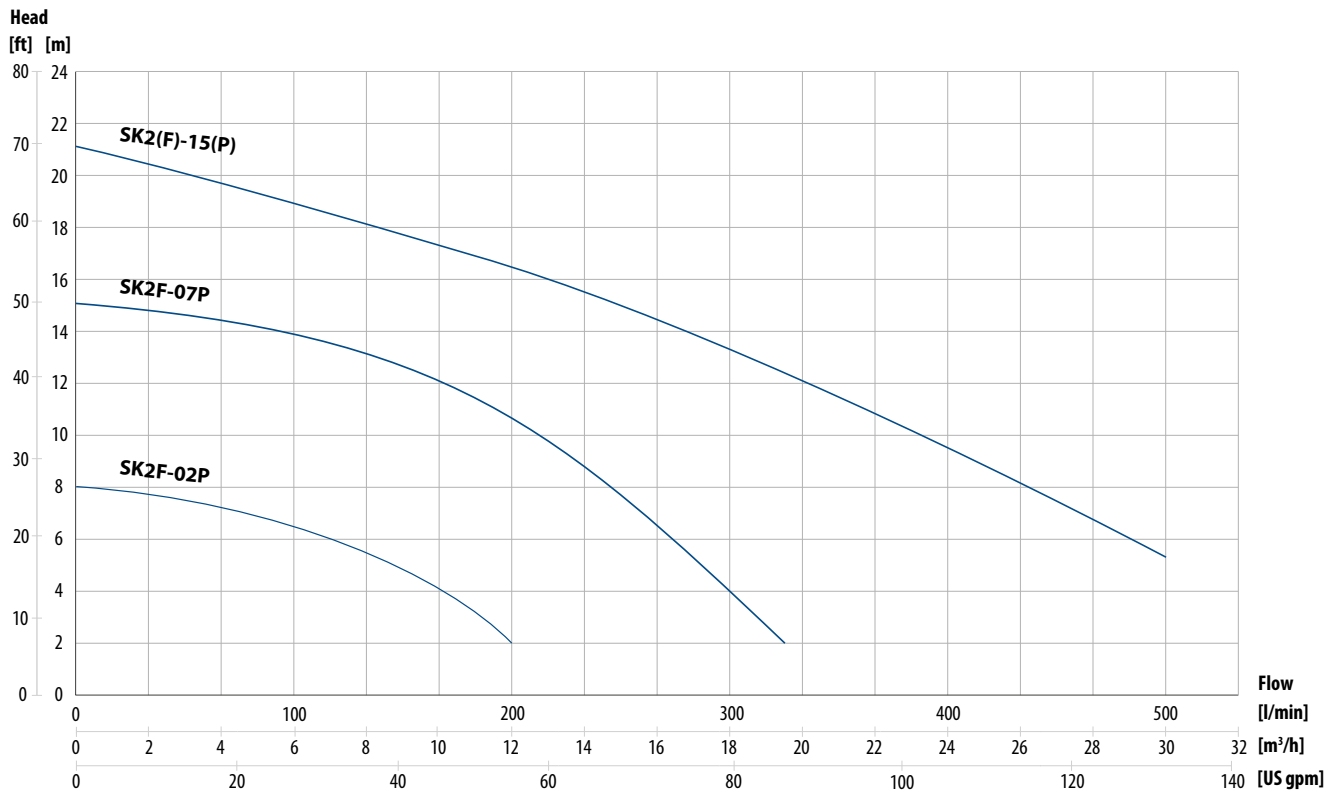

Dewatering pumps »

SF series

Tapflo SF is a light and handheld pump that comes with a level control float switch that saves energy and makes it operator free. For maximum durability and maintaining pump performance the pump is equipped with a semi vortex impeller that handles hard particles and minimises wear.

A built-in shaft mounted agitator prevents "air lock" and reduces clogging. SF is supplied with a BSP thread adaptor.

SF is a perfect fit for pumping of groundwater, rainwater, and slightly sandy water.



Fast facts

Capacity:	Up to 16 m ³ /h
Head:	Up to 18 m
Power:	0.4/ 0.75 kW, single-phase 220 V ± 10 %, 50 Hz
Insulation class:	F
Protection class:	IP 68
Outlet:	50 mm/ 2"
Water temperature:	Up to 40 °C
Max water depth:	10 m
Cable length:	8 m

Dimensions

Model (50 Hz)	Height (H)	Width (W)	Weight (net)	Outlet (ød)	BSP thread (ød)	Continuous running water level (W1)
	mm	mm	Kg	mm	in	mm
SF2F-04P	365	237	13.5	50	2	85
SF2F-07P	390	257	16.5	50	2	85

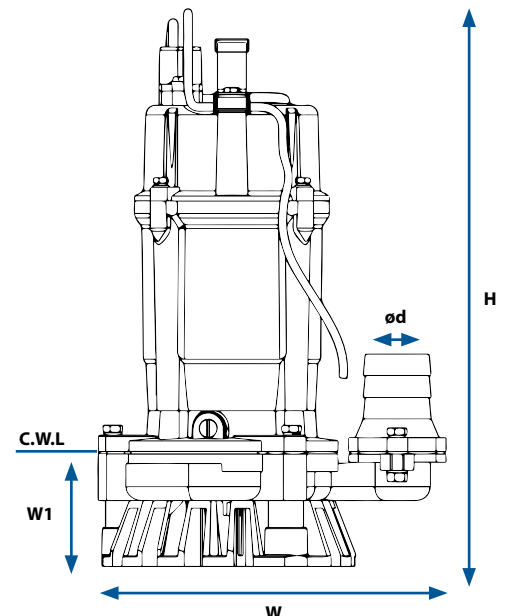

Dewatering pumps >>

Technical data

Model (50 Hz)	Level control	Motor power	Voltage	Rated Capacity		Rated head m	Max capacity		Max head m	Impeller Passage mm	Max depth m
		kW	V	m ³ /h	l/min		m ³ /h	l/min			
SF2F-04P	Float switch	0.4	220	8	133	8	12.6	210	12	6	10
SF2F-07P	Float switch	0.75	220	10	166	11	16	266	18	6	10

Performance curves - 50 Hz, 2850 rpm

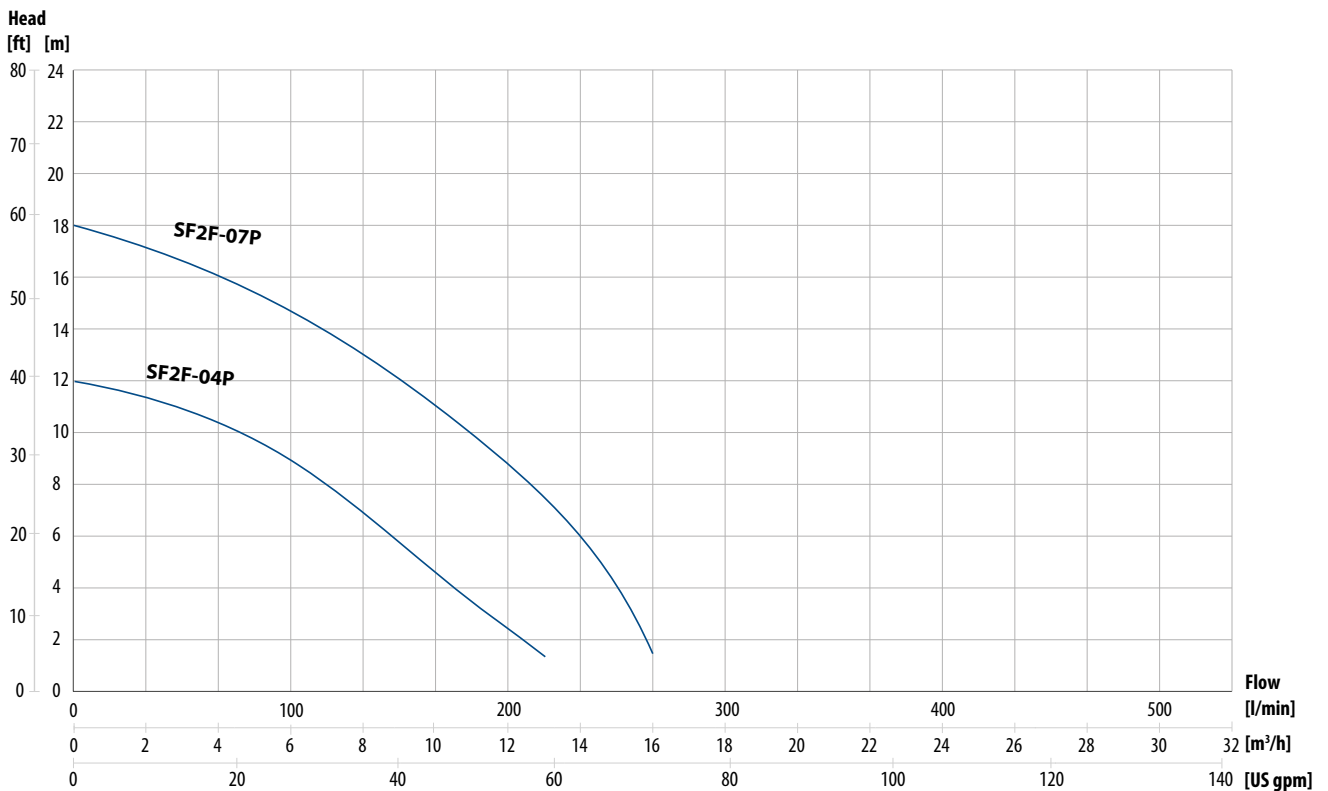

Dewatering pumps »

SB series

Tapflo SB is constructed in rigid cast iron that makes the pump run problem free day after day. The pump has a greatly increased maximum submersion depth due to a mechanical seal that is resistant to high pressure. The impeller is semi-open and made of high chrome alloy match with wear plate (ductile iron) to withstand abrasives.

Discharge channel cast is part of the motor housing which results in effective motor cooling.

Models with outlet up to 80 mm/ 3" includes dual position outlet port, to enable the user to position the discharge hose in the horizontal or vertical direction to avoid hose folding or bending. Same models comes with a BSP thread adaptor.

The motor is hermetically sealed equipped build-in thermal protection. Sizes **SB2-22** to **SB4-37** can be equipped with a level control sensor, marked by (E).



Fast facts

Capacity:	Up to 147 m ³ /h
Head:	Up to 40 m
Power:	1.5-11 kW, three-phase 400 V ± 10 %, 50 Hz
Insulation class:	F
Protection class:	IP 68
Outlet:	50/ 80/ 100/ 150 mm 2"/ 3"/ 4"/ 6"
Water temperature:	Up to 40 °C
Max water depth:	25 m
Cable length:	8 m

Dimensions

Model (50 Hz)	Height (H)	Width (W)	Weight (net)	Outlet (ød)	BSP thread (ød)	Continuous running water level (W1)
	mm	mm	Kg	mm	in	mm
SB2(E)-22	505 (582)	235 (235)	39 (44)	50 (50)	2	120 (120)
SB3(E)-22	505 (582)	235 (235)	39 (44)	80 (80)	3	120 (120)
SB2(E)-37	629 (707)	283 (283)	63 (71)	50 (50)	2	150 (150)
SB3(E)-37	629 (707)	283 (283)	63 (71)	80 (80)	3	150 (150)
SB4(E)-37	629 (707)	283 (283)	63 (72)	100 (100)	4	150 (150)
SB4-55	590	283	77	100	4	150
SB4-75	676	330	106	100	4	190
SB6-75	676	330	108	150	6	190
SB6-11	695	373	139	150	6	139

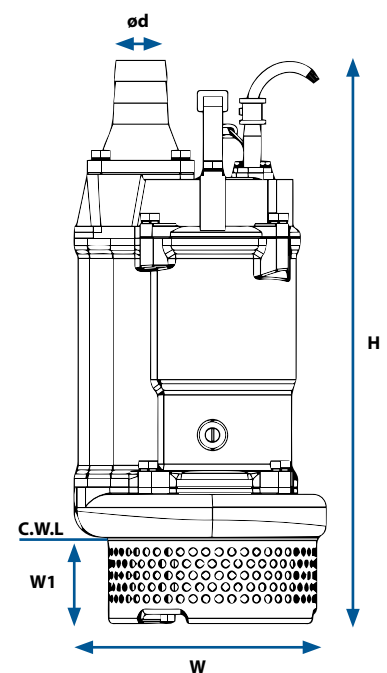

Dimensions for pumps equipped with level control sensor (E) is presented inside the brackets.

Dewatering pumps >>

Technical data

Model (50 Hz)	Level control	Motor power kW	Voltage V	Rated Capacity		Rated head m	Max capacity		Max head m	Impeller Passage mm	Max depth m
				m ³ /h	l/min		m ³ /h	l/min			
SB2(E)-22	(E) Sensor	2.2	400	18	300	20	33	550	26	8.5	25
SB3(E)-22	(E) Sensor	2.2	400	36	600	11	55	920	19	8.5	25
SB2(E)-37	(E) Sensor	3.7	400	12	200	30	33	550	34	8.5	25
SB3(E)-37	(E) Sensor	3.7	400	30	500	20	55	920	29	8.5	25
SB4(E)-37	(E) Sensor	3.7	400	60	1000	11.5	90	1500	18.5	8.5	25
SB4-55	-	5.5	400	60	1000	16	105	1750	23	8.5	25
SB4-75	-	7.5	400	48	800	30	84	1400	40	11.5	25
SB6-75	-	7.5	400	90	1500	15	124.8	2080	31	19.5	25
SB6-11	-	11	400	102	1700	22	147	2450	32	19.5	25

Performance curves - 50 Hz, 2850 rpm

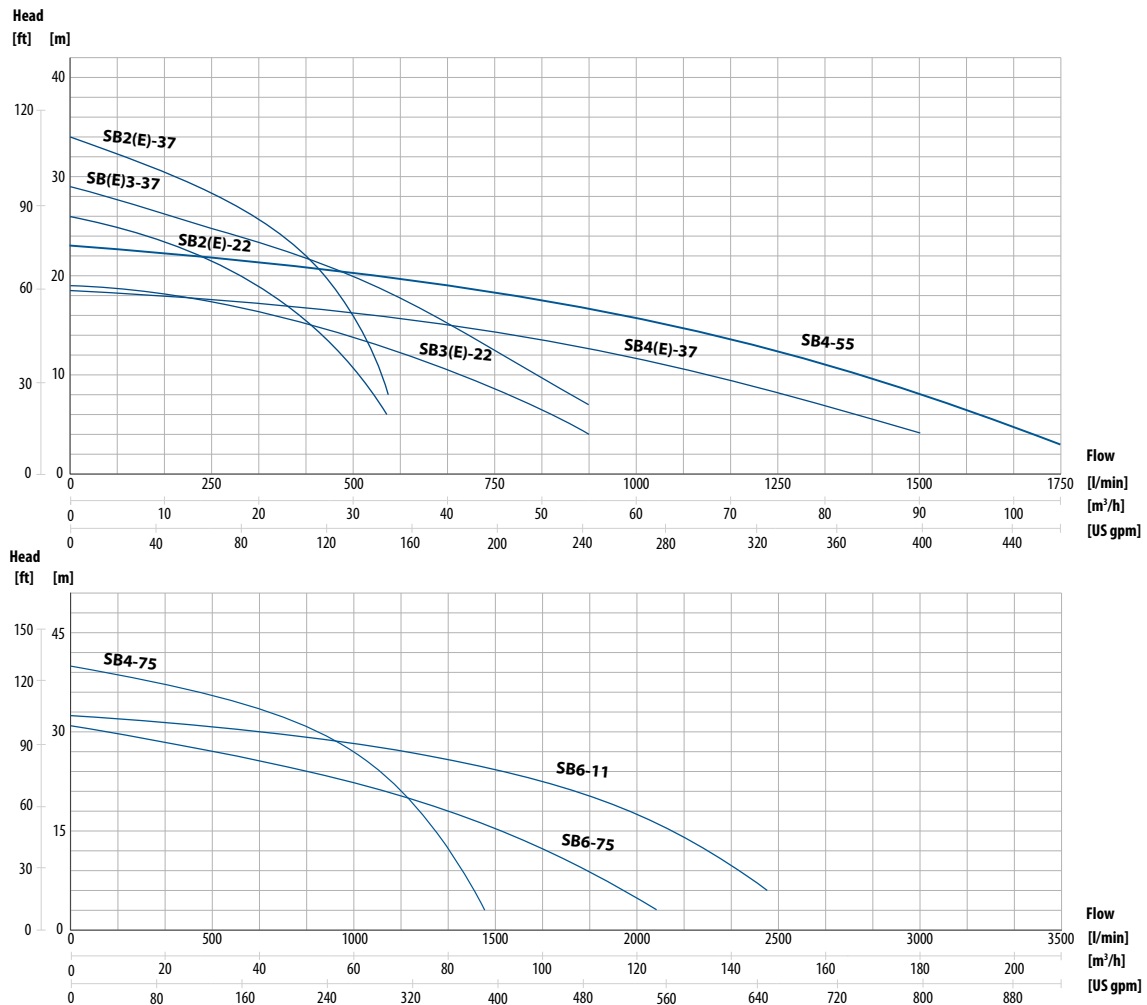

Sludge & Slurry pumps

Pumps that handles slurry, sludge, bentonite and sand carrying water that are often used in mines and quarries, construction, tunneling, industry processing and hire fleets

SFA series

Tapflo SFA is an effective compact and handheld pump for muddy water. Impeller and agitator are manufactured in strong chrome alloy to withstand sand and abrasive materials.

SFA is supplied with a level control float switch that saves energy and makes it operator free as well as an optional BSP thread adaptor to use instead of hose connection.

A semi-vortex impeller in combination with agitator minimises sludge clogging.



Fast facts

Capacity:	13.2 m ³ /h
Head:	13 m
Power:	0.55 kW, single-phase 220 V ± 10 %, 50 Hz
Insulation class:	F
Protection class:	IP 68
Outlet:	50 mm/ 2"
Water temperature:	Up to 40 °C
Max water depth:	10 m
Cable length:	8 m

Dimensions

Model (50 Hz)	Height (H)	Width (W)	Weight (net)	Outlet (ød)	BSP thread (ød)	Continuous running water level (W1)
	mm	mm	Kg	mm	in	mm
SFA2F-05P	405	237	15.5	50	2	95

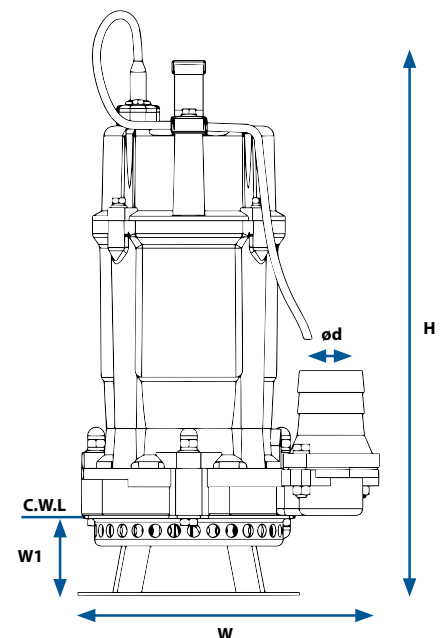

Technical data

Model (50 Hz)	Level control	Motor power	Voltage	Rated Capacity		Rated head	Max capacity		Max head	Impeller Passage	Max depth
		kW	V	m ³ /h	l/min	m	m ³ /h	l/min	m	mm	m
SFA2F-05P	Float switch	0.55	220	8	133	8	13.2	220	13	9	10

Performance curves - 50 Hz, 2850 rpm

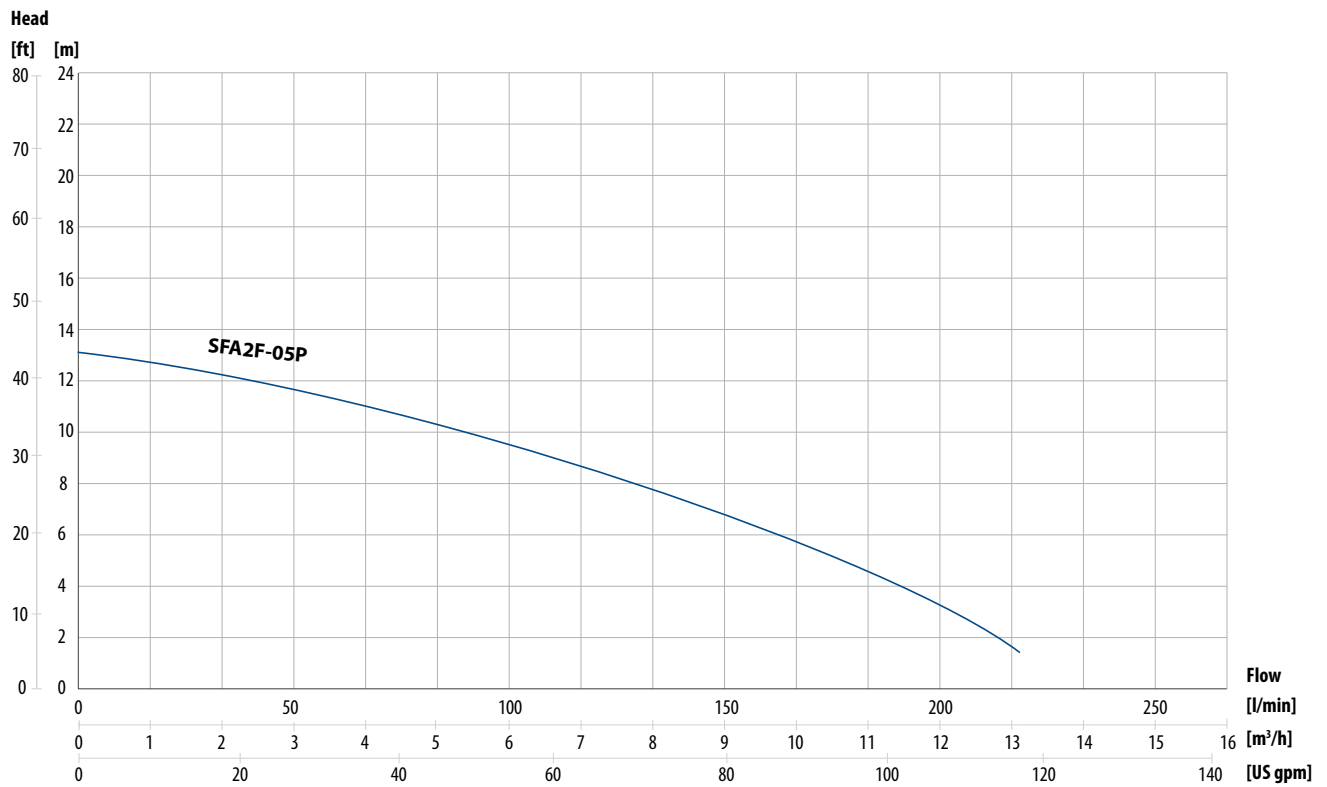

Sludge & Slurry pumps >>

SBA series

Tapflo SBA is a heavy-duty slurry and sludge pump made in cast iron, employing the SB series as its base. On SBA an agitator is provided to assist smooth suction of the pumped fluid.

The side-flow, top-discharge design keeps the motor cool even if the pump is operated continuously with its motor exposed in air, and it makes the pump easier to place in a confined space.

SBA includes dual position outlet port, to enable the user to position the discharge hose in the horizontal or vertical direction to avoid hose folding or bending. The pump is supplied with a BSP thread adaptor.

Impeller and agitator manufactured in strong chrome alloy to withstand abrasives and a semi-vortex impeller in combination with agitator minimises clogging.

SBA can be equipped with a level control sensor, marked by (E).



Fast facts

Capacity:	Up to 60 m ³ /h
Head:	Up to 30 m
Power:	2.2/3.7 kW, three-phase 400 V ± 10 %, 50 Hz
Insulation class:	F
Protection class:	IP 68
Outlet:	50 mm/ 80 mm 2"/ 3"
Water temperature:	Up to 40 °C
Max water depth:	25 m
Cable length:	8 m

Dimensions

Model (50 Hz)	Height (H)	Width (W)	Weight (net)	Outlet (ød)	BSP thread (ød)	Continuous running water level (W1)
	mm	mm	Kg	mm	in	mm
SBA2(E)-22	557 (629)	234 (235)	40 (46)	50 (50)	2	135 (135)
SBA3(E)-37	636 (720)	283 (283)	64 (72)	80 (80)	3	165 (165)

Dimensions for pumps equipped with level control sensor (E) is presented inside the brackets.

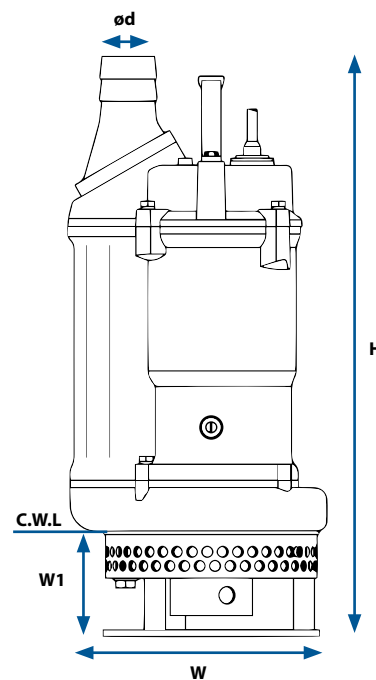

Sludge & Slurry pumps >>

Technical data

Model (50 Hz)	Level control	Motor power	Voltage	Rated Capacity		Rated head	Max capacity		Max head	Impeller Passage	Max depth
		kW	V	m ³ /h	l/min	m	m ³ /h	l/min	m	mm	m
SBA2(E)-22	(E) Sensor	2.2	400	18	300	19	30	500	25	10	25
SBA3(E)-37	(E) Sensor	3.7	400	30	500	20	60	1000	30	10	25

(E): Pump equipt with level control sensor

Performance curves - 50 Hz, 2850 rpm

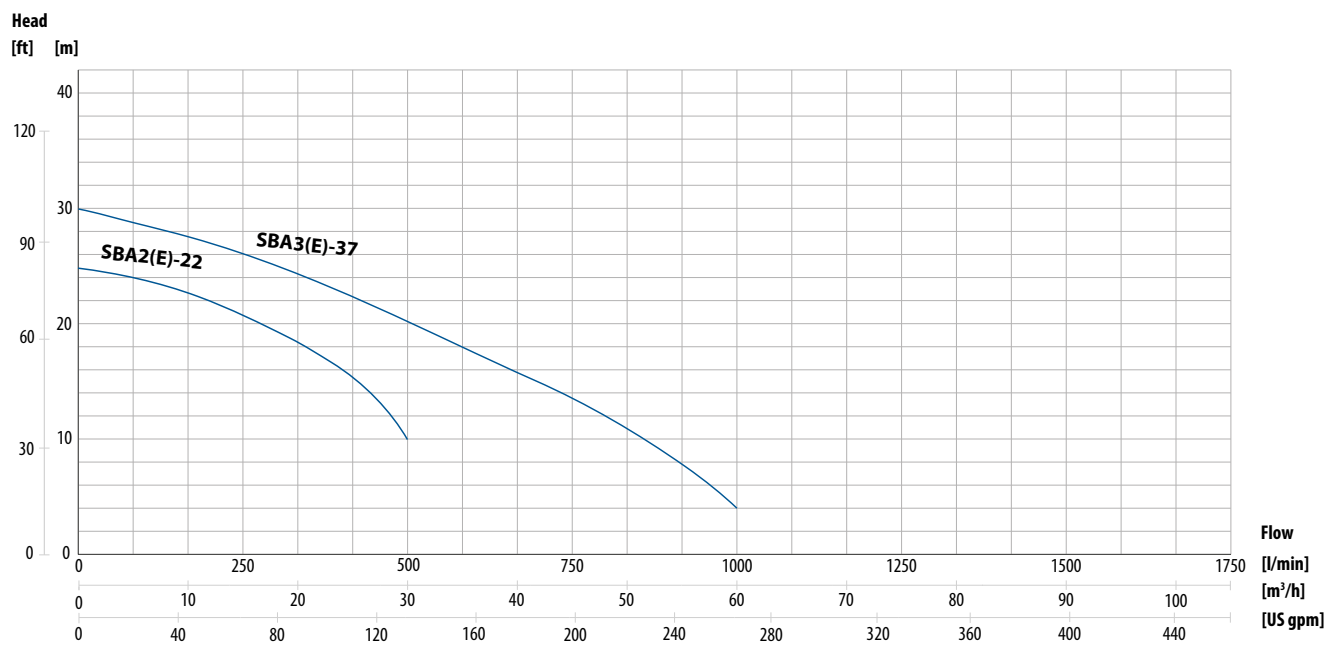

Sweden

Filaregatan 4 | S-442 34 Kungälv

Tel: +46 303 63390

Fax: +46 303 19916

E-mail addresses:

Commercial questions: sales@tapflo.com

Orders: order@tapflo.com

Tech support: support@tapflo.com

Tapflo products and services are available worldwide.

Tapflo is represented by own Tapflo Group Companies and carefully selected distributors assuring highest Tapflo service quality for our customers' convenience.

AUSTRALIA | AUSTRIA | AZERBAIJAN | BAHRAIN | BELARUS | BELGIUM | BOSNIA | BRAZIL | BULGARIA | CANADA | CHILE | CHINA | COLOMBIA | CROATIA | CZECH REPUBLIC | DENMARK | ECUADOR | EGYPT | ESTONIA | FINLAND | FRANCE | GREECE | GEORGIA | GERMANY | HONG-KONG | HUNGARY | ICELAND | INDIA | INDONESIA | IRELAND | ISRAEL | ITALY | JAPAN | JORDAN | KAZAKHSTAN | KUWAIT | LATVIA | LIBYA | LITHUANIA | MACEDONIA | MALAYSIA | MEXICO | MONTENEGRO | MOROCCO | NETHERLANDS | NEW ZEALAND | NORWAY | POLAND | PORTUGAL | PHILIPPINES | QATAR | ROMANIA | RUSSIA | SAUDI ARABIA | SERBIA | SINGAPORE | SLOVAKIA | SLOVENIA | SOUTH AFRICA | SOUTH KOREA | SPAIN | SWEDEN | SWITZERLAND | TAIWAN | THAILAND | TURKEY | UKRAINE | UNITED ARAB EMIRATES | UNITED KINGDOM | USA | UZBEKISTAN | VIETNAM

Tapflo Group Companies

Australia

Tapflo Oceania (Pty) Ltd.
Tel: +61 1800303633
sales@tapflo.com.au

Austria

Tapflo GmbH
Tel: +43 73227292910
sales@tapflo.at

Baltic States

Tapflo SIA
Tel: +371 67472205
sales@tapflo.lv

Belarus

Tapflo LLC
Tel: +375 173934609
sales@tapflo.by

Belgium

Tapflo Benelux B.V.
Tel: +31 (0)850074300
info@tapflo.nl

Bulgaria

Tapflo E00D
Tel: +359 (0)29741854
office@tapflo.bg

Canada

Tapflo Canada
Tel: +1 5148135754
canada@tapflo.com

China

Tapflo (Wuxi) Pumps Co. Ltd.
Tel: +86 51082417072
sales@tapflo.cn

Croatia

Tapflo d.o.o.
Tel: +385 914884666
sales@tapflo.hr

Czech Republic

Tapflo s.r.o.
Tel: +420 513033924
tapflo@tapflo.cz

Denmark

Tapflo Danmark ApS
Tel: +45 36454600
info@tapflo.dk

France

Sarl Tapflo France
Tel: +33 134788240
info@tapflo.fr

Hungary

Tapflo Kft.
Tel: +36 30148 8551
office@tapflo.hu

India

Tapflo Fluid Handling India Pvt Ltd.
Tel: +91 2065000215
ac@tapflo.in

Ireland

Tapflo Ireland Ltd.
Tel: +353 12011911
info@tapflo.ie

Italy

Tapflo Italia S.r.l.
Tel: +39 0362306528
info@tapfloitalia.com

Japan

Tapflo Japan K.K.
Tel: +81 362403510
tapflojp@tapflo.co.jp

Kazakhstan

Tapflo LLP
Tel: +7 7273278347
sales@tapflo.kz

Netherlands

Tapflo Benelux B.V.
Tel: +31 (0)850074300
info@tapflo.nl

Poland

Tapflo Sp. z o.o.
Tel: +48 585304212
info@tapflo.pl

Romania

S.C. Tapflo Rom. S.r.l.
Tel: +40 213451255
sales@tapflo.ro

Russia

Tapflo Company LLP
Tel: +7 4952321828
sales@tapflo.com.ru

Serbia

Tapflo d.o.o.
Tel: +381 21445808
sales@tapflo.rs

Slovakia

Tapflo s.r.o.
Tel: +421 911137883
tapflo@tapflo.sk

Slovenia

Tapflo d.o.o.
Tel: +386 68613474
sales@tapflo.hr

Spain

Tapflo Ibérica S.L.
Tel: +34 918093182
avives@tapfloiberica.es

South Africa

Tapflo (Pty) Ltd.
Tel: +27 317015255
sales@tapflo.co.za

Sweden

Tapflo AB
Tel: +46 (0)30314050
info@tapflo.com

Turkey

Tapflo Makina Ltd.
Tel: +90 2164673311
sales@tapflo.com.tr

Ukraine

Tapflo LLC
Tel: +380 442226844
sales@tapflo.ua

Uzbekistan

Tapflo Uzbekistan
Tel: +998 712370940
sales@tapflo.uz

United Kingdom

Tapflo (UK) Ltd.
Tel: +44 2380252325
sales@tapflo pumps.co.uk



If your country is not listed please visit www.tapflo.com/en/contact

www.tapflo.com

Tapflo is a registered trademark of Tapflo AB. All rights reserved.

Information in this document is subject to change without notice. Reproduction in any manner without written permission of Tapflo Group is forbidden. Tapflo Group reserves the right to make changes in product design, or detail, and to discontinue any product or material without notice.

Art. No. 10-2234