

tapflo®

# CUSTOMIZED FLOW SYSTEMS

edition 2016

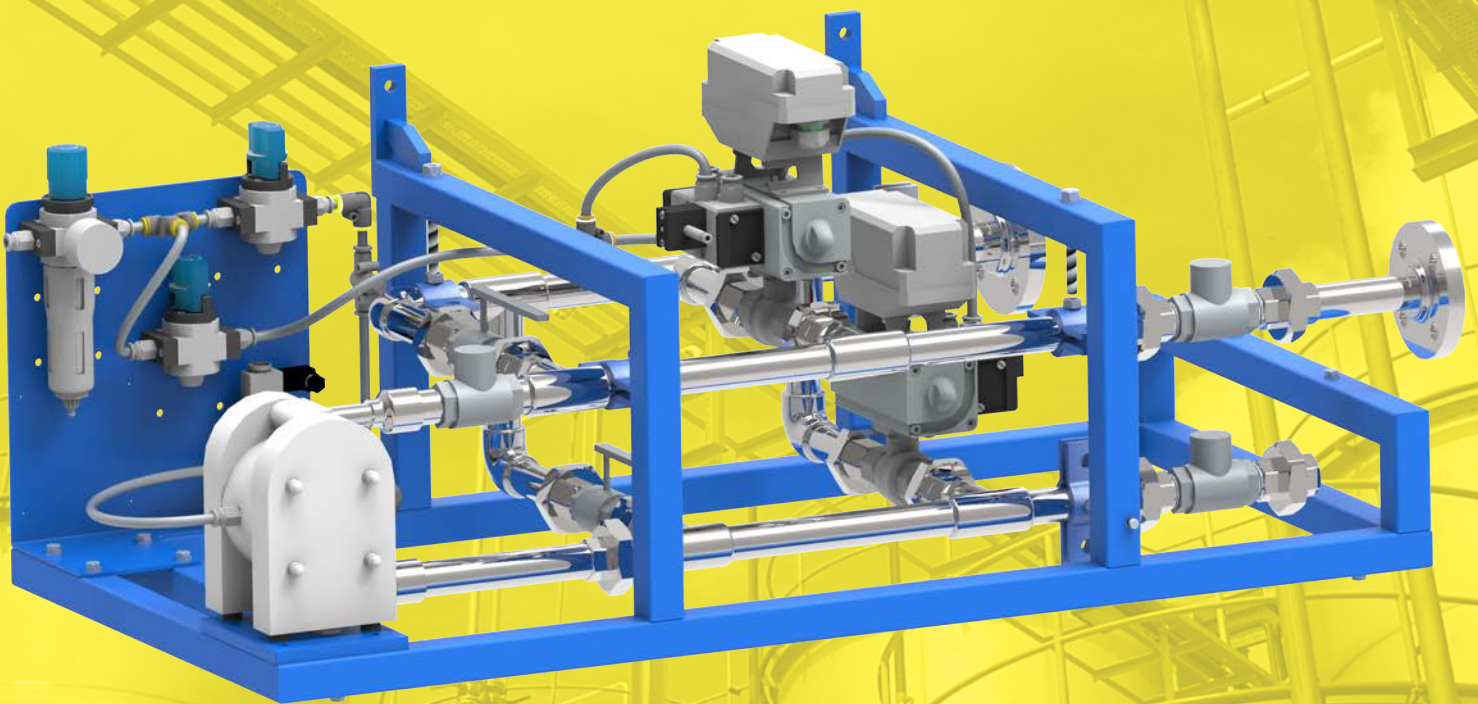

» All about your flow

[www.tapflo.com](http://www.tapflo.com)

## All about your flow

Tapflo is a leading pump manufacturer with the ambition to provide a wide range of premium products for various industrial applications. We focus on delivering the best fluid processing solutions and support on all stages of the process, worldwide.



## About Tapflo

Tapflo is an independent, Swedish, family owned, manufacturer and global supplier of air operated diaphragm pumps, centrifugal pumps and other industrial process equipment. The company was founded in Kungälv, Sweden in 1980 and has since then been working with design and manufacture of thermoplastic, metal and sanitary series diaphragm pumps and also with complete range of centrifugal pumps and industrial equipment. After years of dynamic development the company evolved into Tapflo Group with worldwide operations. Tapflo Group is represented by own companies and independent distributors all over the world on 6 continents.

## Quality certified

At Tapflo we believe that quality is one of the highest values, both for our customers as well as our employees. As a result, we comply with various globally recognised certification and quality control institutions. Many of our products comply with EC ATEX directives for equipment intended for use in explosion hazardous environments.

The aseptic series is EHEDG certified (European Hygienic Engineering & Design Group), the pharmaceutical series has USP VI and EC 1935/2004 approval.

All our products are obviously CE marked and followed by our comprehensive instruction manuals. Tapflo manufacturing process is certified according to ISO 9001:2009.



## Our values

### ■ Long term engagement is our core

Our aim is to continuously provide premium products according to evolving needs of our customers. That is why we see each customer relationship as a long term commitment.

### ■ Local means on your terms

Tapflo is your global partner providing local support. No matter where your plant is located you can expect us to support you locally.

### ■ Flexibility the foundation of good service

We are prepared to deal with reality, knowing that in practice this means answering questions, offering solutions and supplying spare parts with a minimal loss of time.

### ■ Customizing to bring the product to the needs

Our intention is always to help our clients find the most cost effective solutions to increase their company's efficiency. If this means changing the design of the pump we see it as a challenge - not a problem.

### ■ To produce is to develop

When you are actively involved in the manufacturing of a product, it is almost impossible not to discover ways to improve it. This allows us to frequently offer solutions that are even more sustainable and efficient.

# Customized Flow Systems

Reliability and safety are found as the most desired characteristics of devices applied in industrial processes. To meet customers' need, Tapflo offers tailor-made flow systems of the highest quality. Our mission is to provide technical solutions that guarantee proper functionality and stable operation in every environment.

**Tapflo solutions are successfully applied in the following applications:**

**Industrial sector:**

- Chemical processing industry
- Oil & Gas
- Mechanical industry
- Surface treatment
- Pulp & paper industry
- Paint, print & varnish industry
- Waste water treatment



The image shows a worker in a white hard hat and safety vest in an industrial setting. To the right is a blue icon of a factory building with a chimney and three windows.

**Hygienic & sanitary sector:**

- Food, beverages & drinks
- Dairy, milk & ice cream
- Pharmaceutical industry
- Cosmetics industry
- Processed food



The image shows a worker in a white lab coat and cap in a clean industrial environment. To the right is a blue icon of a tomato and a bottle.



# Tapflo Integrated Solutions

Tapflo offers integrated solutions as an possibility to apply standard devices in non-standard applications.

Combining different flow components into one complex unit is an opportunity to suit individual customers' needs, that are related to:

- » Required equipment & functionality
- » Available space
- » Position of connecting flanges
- » Mobility

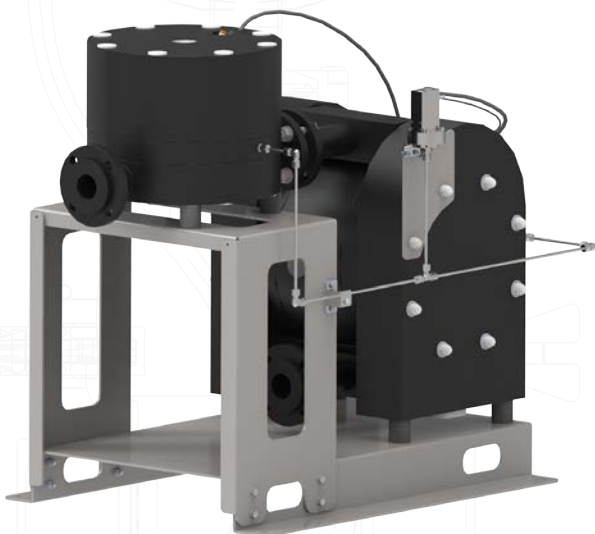

■ **TXB400+DTBX400:**  
integrated with pneumatic Diaphragm Failure Monitoring System (PDFM).



■ **T425+DT425:**  
integrated with air pressure booster, built on a hygienic frame.

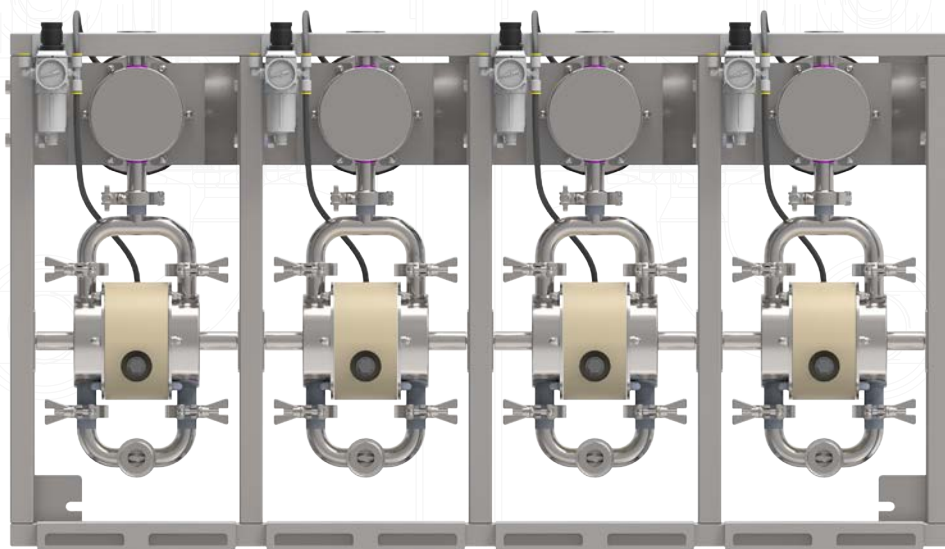

■ **4x T80+DT80:**  
assembled on a hygienic frame with removable drip pans.

# Tapflo Integrated Solutions



Tapflo biggest pumps & dampeners now available as integrated units!



- **T800+DT800 & T820+DT820:** built on one support frame with footprint reduced to less than 0,6 m<sup>2</sup>!

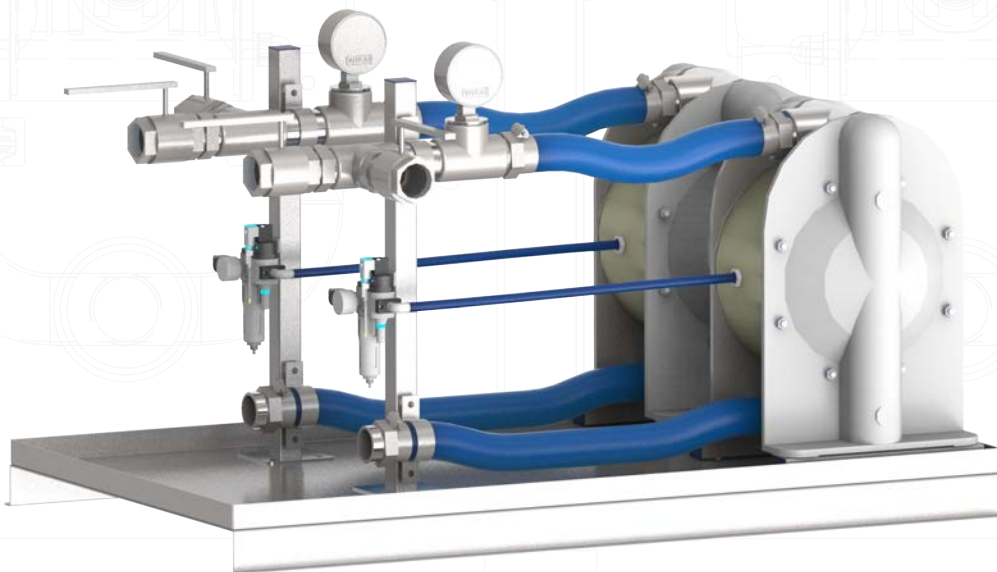

- **2xT420:** Compact assembly on a support frame with a drip pan. Ball valves and pressure indicators included to meet customer's needs.

# SKID - Customized Process Units

## Main elements of Tapflo pumping SKID

Every need for a non-standard pumping system is an opportunity for us to create a unique, made-to-measure SKID.

Tapflo Engineering to Order team has developed a complex unloading solution, that is successfully used to unload barrels containing various chemicals. Tapflo AODD pump is a heart of this process.

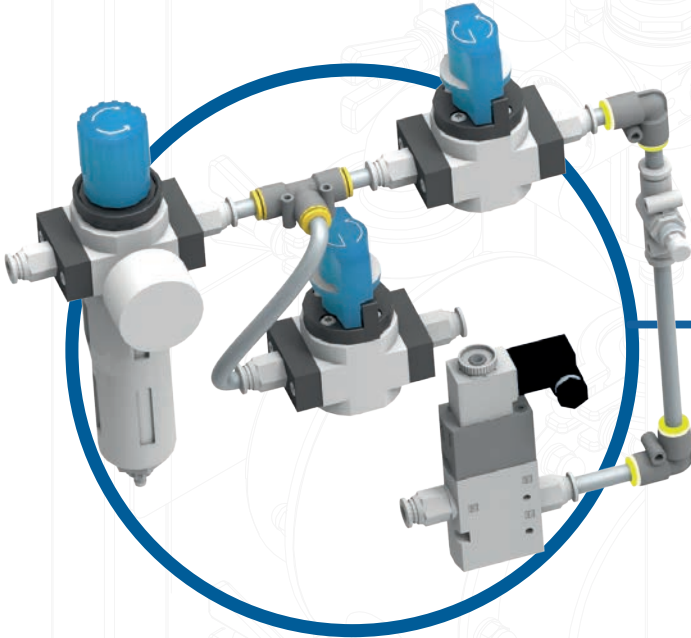

### Pneumatic or electric control system:

To optimize the process and have control over it. The pump is stopped after each barrel is emptied. After that the pipelines are flushed with water.



### Tapflo pump:

It is the heart of Your process. Tapflo AODD pumps can handle almost every liquid.

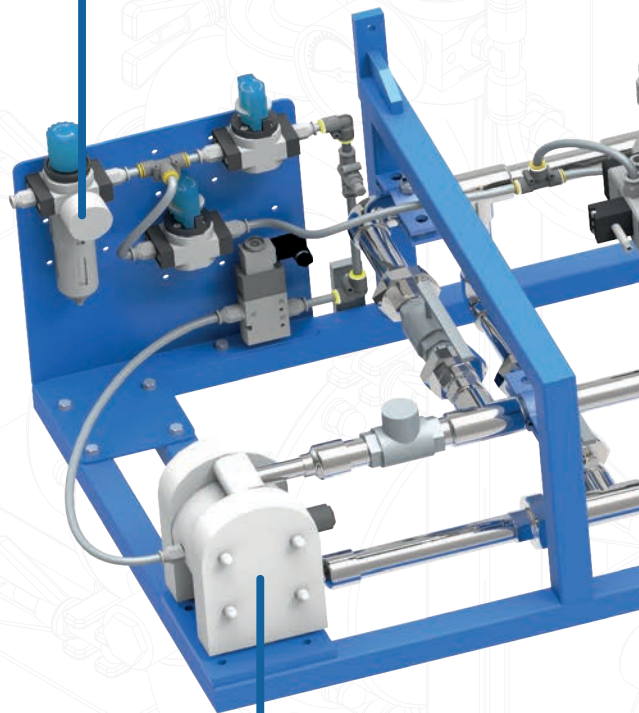



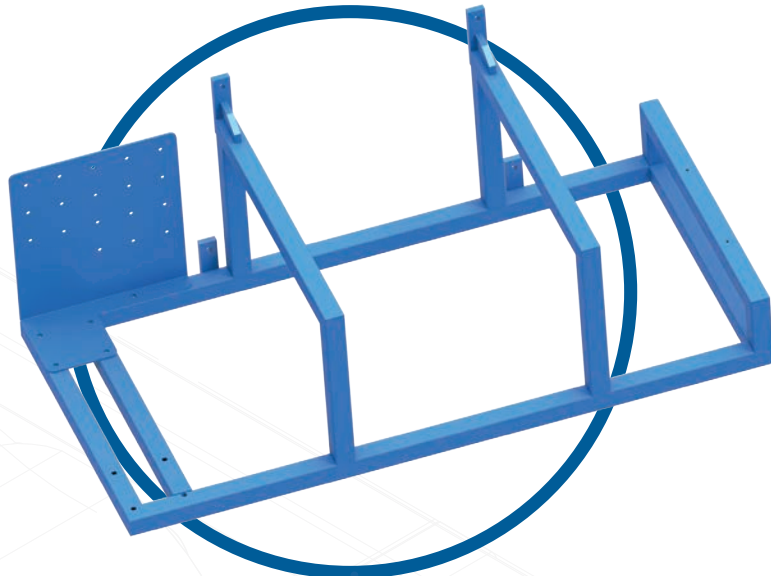

**Support frame:**

To keep the unit steadily and fit it to available space. Both industrial & hygienic standards are available.

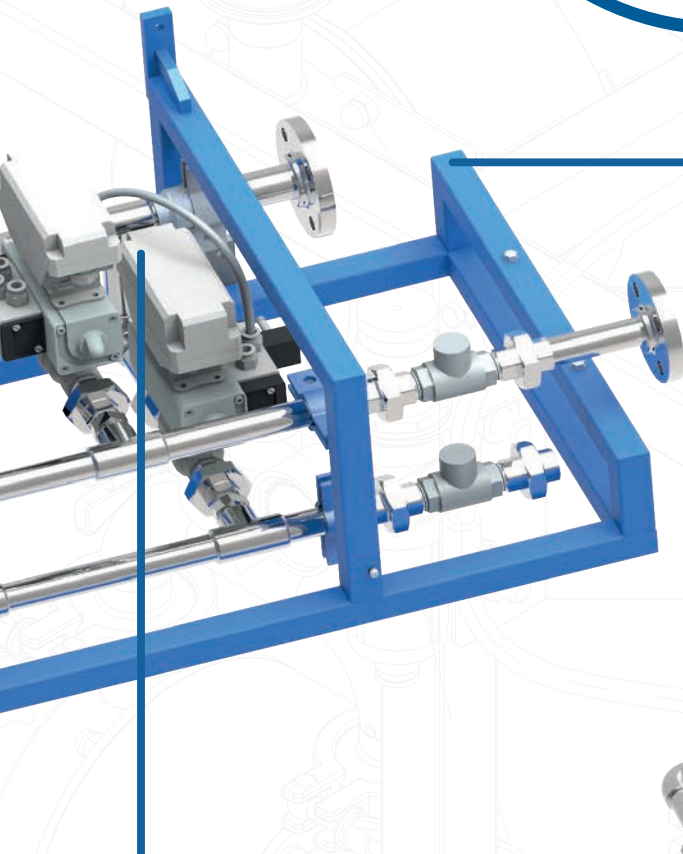

**Control valves & pipelines:**

As we care about proper flow properties, pipelines in every SKID unit are being analyzed and adjusted to obtain the best possible hydraulic conditions.

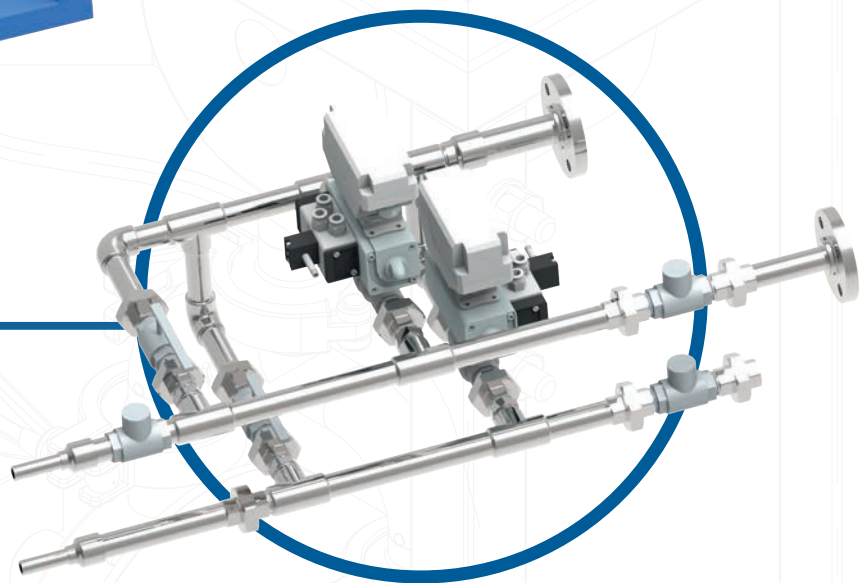

# SKID - Customized Process Units

## Sample solutions

Based on strong experience in design and production, Tapflo offers wide range of compact process pumping systems.

We create units that are dedicated to certain applications in certain industrial sectors. In Tapflo we provide almost limitless possibilities of pump units' development, both in mechanical & automation disciplines.

In addition, Tapflo might take responsibility for project management, assembly works and integration with existing on site systems.



**"WE WORK IN  
A TURN-KEY  
STANDARD"**

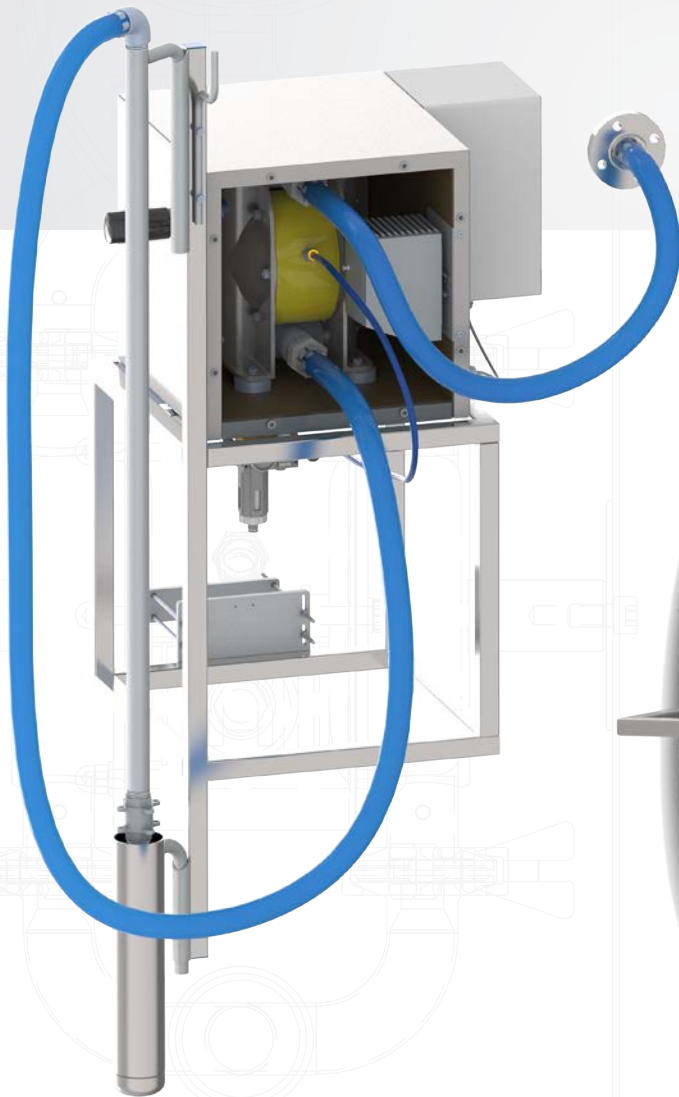

### ■ IBC containers unloading unit

Including **Tapflo T120** pump built in a temperature proof box with a control panel. Ready to work in low ambient temperatures.

### ■ Mobile mixing & unloading tank

**Tapflo CTV 40-13.5** pump to operate in paint industry.



# SKID - Customized Process Units

## Sample solutions



**"TAPFLO BRINGS  
FUNCTIONALITY"**

### ■ Ethanol dispensing and filtering unit:

**Tapflo TRX20** pump unloading a container at pharmaceutical factory. ATEX-approved unit.

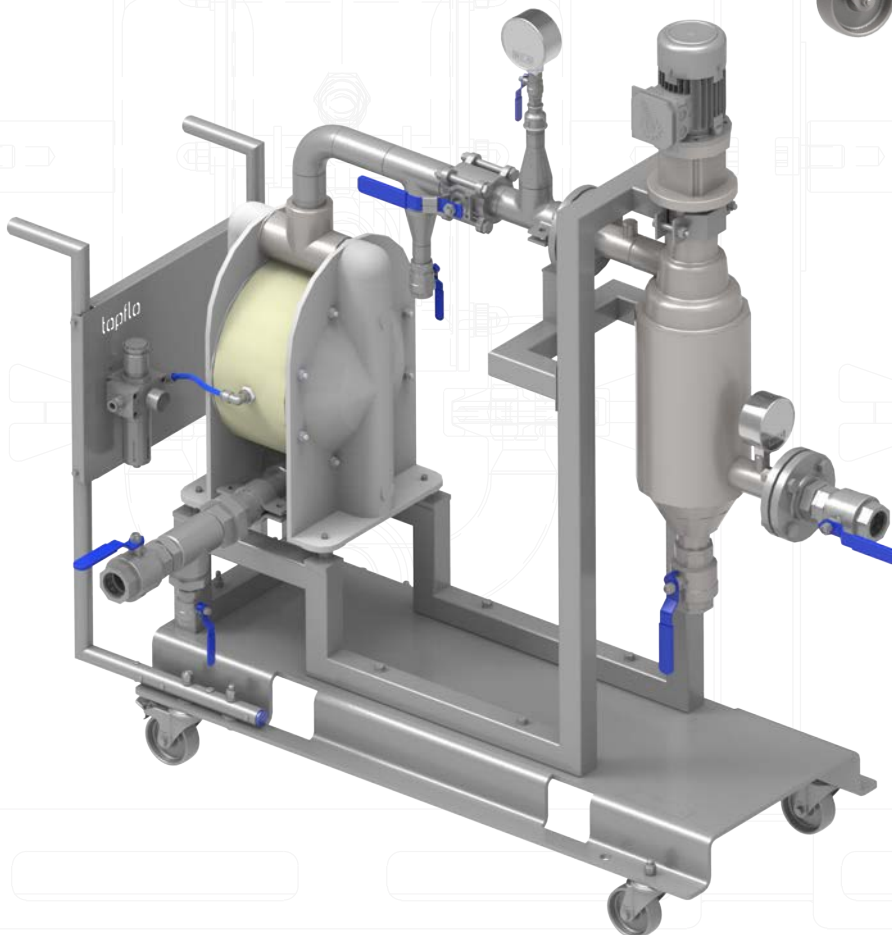

### ■ Mobile filtration unit:

**Tapflo T420** pump supplying paint resin through a self-cleaning filter.

# Tapflo Automation & Control Solutions

Tapflo is proud to announce, that we have broadened our offer with automation & control solutions.

By using both pneumatic and electric devices to monitor flow parameters, we are able to ensure safe work of all Tapflo pump units.

## » Air Operated Double Diaphragm Pumps



■ Pneumatic Diaphragm Failure Monitoring System (PDFM)

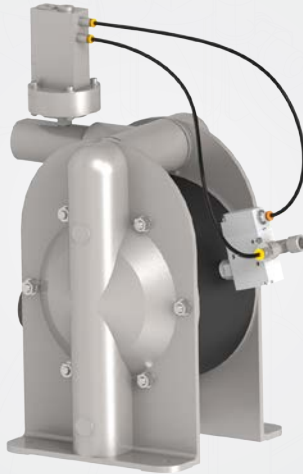

■ Pneumatic Dry-Run & Dead Head Protection Systems (PDRN, PDHR, PDHS)

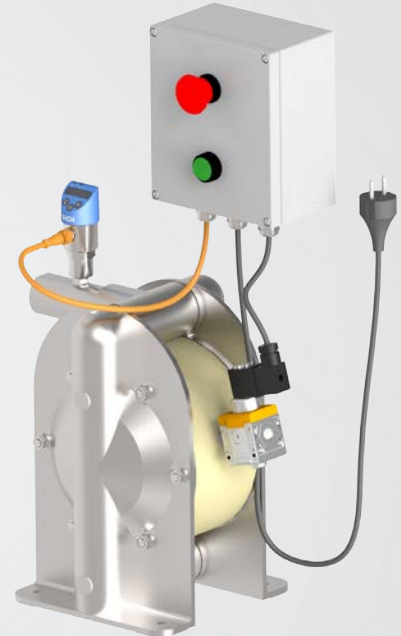

■ Electronic Dry Run & Dead Head protection system (EDHR)

## » Centrifugal Pumps

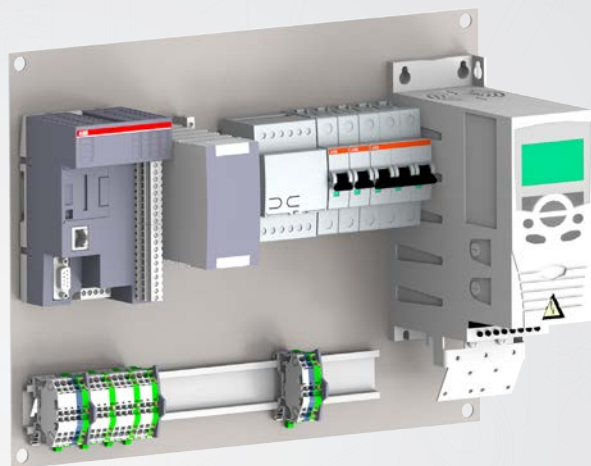

**Stainless and painted steel control cabinets available!**

- » Built-in frequency inverter
- » Start & stop pushbuttons
- » Main switch: padlockable in OFF position for service purpose
- » Configured according to customer's guidelines

# Product range

## Diaphragm pumps



**PE & PTFE pumps**



**Metal pumps**



**Pharmaceutical pumps**



**Sanitary pumps**



**Powder pumps**

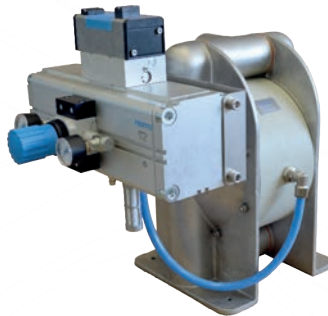

**TF Filter press pump**



**EHEDG aseptic pumps**

## Centrifugal pumps



**CTI & CTH centrifugal pumps**



**CTM magdrive centrifugal pumps**



**CTV vertical centrifugal pumps**



**CTS Self-priming CT pump**  
CTS H - Hygienic version



**CTS Self-priming CT pump**  
CTS I - Industrial version



**FTA Filter unit**



# TAPFLO AB

## Sweden

Filaregatan 4 | S-442 34 Kungälv

Tel: +46 303 63390

Fax: +46 303 19916

E-mail addresses:

Commercial questions: [sales@tapflo.com](mailto:sales@tapflo.com)

Orders: [order@tapflo.com](mailto:order@tapflo.com)

Tech support: [support@tapflo.com](mailto:support@tapflo.com)

## Tapflo products and services are available in 75 countries on 6 continents.

Tapflo is represented worldwide by own Tapflo Group Companies and carefully selected distributors assuring highest Tapflo service quality for our customers' convenience.

AUSTRALIA | AUSTRIA | AZERBAIJAN | BAHRAIN | BELARUS | BELGIUM | BOSNIA | BRAZIL | BULGARIA | CANADA | CHILE | CHINA | COLOMBIA | CROATIA | CZECH REPUBLIC | DENMARK | ECUADOR | EGYPT | ESTONIA | FINLAND | FRANCE | GREECE | GEORGIA | GERMANY | HONG-KONG | HUNGARY | ICELAND | INDIA | INDONESIA | IRAN | IRELAND | ISRAEL | ITALY | JAPAN | JORDAN | KAZAKHSTAN | KUWAIT | LATVIA | LIBYA | LITHUANIA | MACEDONIA | MALAYSIA | MEXICO | MONTENEGRO | MOROCCO | THE NETHERLANDS | NEW ZEALAND | NORWAY | POLAND | PORTUGAL | PHILIPPINES | QATAR | ROMANIA | RUSSIA | SAUDI ARABIA | SERBIA | SINGAPORE | SLOVAKIA | SLOVENIA | SOUTH AFRICA | SOUTH KOREA | SPAIN | SUDAN | SWEDEN | SWITZERLAND | SYRIA | TAIWAN | THAILAND | TURKEY | UKRAINE | UNITED ARAB EMIRATES | UNITED KINGDOM | USA | UZBEKISTAN | VIETNAM

## Tapflo Group Companies

### Austria

Tapflo Austria

Tel: +43 732 27292910

[sales@tapflo.at](mailto:sales@tapflo.at)

### Croatia

Tapflo GmbH

Tel: +385 91 4884 666

[sales@tapflo.hr](mailto:sales@tapflo.hr)

### India

Tapflo Fluid Handling India Pvt Ltd

Tel: +91 20 65000215

[ad@tapflo.in](mailto:ad@tapflo.in)

### Romania

S.C. Tapflo Rom. S.r.l.

Tel: +40 21 3451255

[sales@tapflo.ro](mailto:sales@tapflo.ro)

### South Africa

Tapflo (Pty) Ltd

Tel: +27 31 701 5255

[sales@tapflo.co.za](mailto:sales@tapflo.co.za)

### Azerbaijan

Tapflo Azerbaijan LLC

Tel: +994 502660799

[sales@tapflo.az](mailto:sales@tapflo.az)

### Czech Republic

Tapflo s.r.o.

Tel: +420 513 033 924

[tapflo@tapflo.cz](mailto:tapflo@tapflo.cz)

### Ireland

Tapflo Ireland Ltd

Tel: +353 1 2011911

[info@tapflo.ie](mailto:info@tapflo.ie)

### Russia

Tapflo Company

Tel: +7 495 232 18 28

[sales@tapflo.com.ru](mailto:sales@tapflo.com.ru)

### Turkey

Tapflo Makina Ltd

Tel: +90 216 467 33 11

[sales@tapflo.com.tr](mailto:sales@tapflo.com.tr)

### Baltic States

Tapflo Latvia

Tel: +371 67472205

[sales@tapflo.lv](mailto:sales@tapflo.lv)

### China

Tapflo (Wuxi)

Tel: +86 510 8241 7602

[sales@tapflo.cn](mailto:sales@tapflo.cn)

### Italy

Tapflo Italia

Tel: +39 0362307698

[info@tapfloitalia.com](mailto:info@tapfloitalia.com)

### Serbia

Tapflo d.o.o.

Tel: +381 21 44 58 08

[sales@tapflo.rs](mailto:sales@tapflo.rs)

### Ukraine

TOB Tapflo

Tel: +380 44 222 68 44

[sales@tapflo.com.ua](mailto:sales@tapflo.com.ua)

### Belarus

Tapflo Belarus

Tel: +375 17 3934609

[sales@tapflo.by](mailto:sales@tapflo.by)

### Denmark

Tapflo Danmark

Tel: +45 36 454600

[info@tapflo.dk](mailto:info@tapflo.dk)

### Japan

Tapflo Japan K.K.

Tel: +81-3-6240-3510

[tapflojp@tapflo.co.jp](mailto:tapflojp@tapflo.co.jp)

### Slovakia

Tapflo s.r.o.

+421 911 137 883

[tapflo@tapflo.sk](mailto:tapflo@tapflo.sk)

### Uzbekistan

Tapflo Uzbekistan

Tel: +998 712370940

[sales@tapflo.uz](mailto:sales@tapflo.uz)

### Bulgaria

Tapflo EOOD

Tel: +359 (0)2 974 18 54

[office@tapflo.bg](mailto:office@tapflo.bg)

### France

Tapflo France

Tel: +33 1 34 78 82 40

[info@tapflo.fr](mailto:info@tapflo.fr)

### Kazakhstan

Tapflo Kazakstan

Tel: +7 727 3278347

[sales@tapflo.kz](mailto:sales@tapflo.kz)

### Slovenia

Tapflo GmbH

Tel: +386 68 613 474

[sales@tapflo.hr](mailto:sales@tapflo.hr)

### United Kingdom

Tapflo (UK) Ltd

Tel: +44 2380 252325

[sales@tapflo pumps.co.uk](mailto:sales@tapflo pumps.co.uk)

### Canada

Tapflo Canada

Tel: +1 514 813 5754

[canada@tapflo.com](mailto:canada@tapflo.com)

### Georgia

Tapflo Georgia

Tel: +995 577 463010

[sales@tapflo.ge](mailto:sales@tapflo.ge)

### Poland

Tapflo Sp. z o.o.

Tel: +48 58 530 42 12

[info@tapflo.pl](mailto:info@tapflo.pl)

### Spain

Tapflo Iberica

Tel: +34 91 8093182

[avives@tapfloiberica.es](mailto:avives@tapfloiberica.es)