

IOM manual

tapflo®

## FT Filter Units

edition 2018 rev 1



Read this instruction manual carefully,  
before you install and operate the pump



### Filter models:

**FT 80**

**FT 160**

**FT 210**

**FT 355**

» All about your flow

[www.tapflo.com](http://www.tapflo.com)

# CONTENTS

---

0.	GENERAL	4
0.1.	Introduction	4
0.2.	Warning symbols	4
0.3.	Qualification and training of personnel	5
1.	INSTALLATION	6
1.1.	Receiving inspection	6
1.2.	Storage	6
1.3.	Foundation	6
1.4.	Environment	6
1.5.	Suction and discharge piping	6
1.5.1.	Connection of discharge pipe	7
1.5.2.	Connection of suction pipe	7
1.6.	Health and safety	7
1.6.1.	Protection	7
1.6.2.	Electrical safety	7
1.6.3.	Chemical hazard	7
1.6.4.	Dry running	8
1.6.5.	Noise level	8
1.6.6.	Temperature hazards	8
1.6.7.	Rotating parts	8
1.6.8.	Powerful magnetic field	8
1.6.9.	Explosive environment	8
1.7.	Accessories	8
1.7.1.	Electric power	9
1.7.2.	Optional accessories	9
1.8.	Motor connection	9
2.	OPERATION	10
2.1.	Start-up	10
2.1.1.	Starting the unit	10
2.1.2.	Restarting after power shut-off	10
2.2.	Stopping the unit	11
3.	MAINTENANCE	12
3.1.	Inspections	12
3.2.	Transport	12
3.3.	Filter unit disassembly	13

# CONTENTS

---

3.4.	Filter cover opening .....	13
3.5.	Filter cartridge installation / replacement .....	14
3.6.	Filter FTL cartridge installation / replacement .....	15
3.7.	Filter oil absorb installation / replacement .....	15
3.8.	Filter unit assembly .....	15
3.8.1.	Test run .....	16
3.9.	Filter cleaning .....	16
3.10.	Diaphragm separator calibration .....	16
4.	SPARE PARTS .....	17
4.1.	Spare parts – FTA-80 .....	17
4.2.	Spare parts – FTA-160 .....	18
4.3.	Spare parts – FT-210 .....	19
4.3.1.	FTA210 Spare parts – custom inserts .....	20
4.4.	FT355 – spare parts .....	21
4.5.	Recommended spare parts .....	22
4.6.	How to order parts .....	22
5.	DATA .....	23
5.1.	Filter code .....	23
5.2.	Materials, data and limits .....	24
5.3.	Dimensional drawing – FTA-80 .....	24
5.4.	Dimensional drawing – FTA-160 .....	25
5.5.	Dimensional drawing – FTA-210 .....	26
5.6.	Dimensional drawing – FTA-355 .....	27
6.	WARRANTY .....	28
6.1.	Returning parts .....	28
6.2.	Warranty .....	28
6.3.	Warranty form .....	30

## EC DECLARATION OF CONFORMITY 01/EC/FT/2018

Series:

**FT(...)80...; FT(...)160...; FT(...)210...; FT(...)355...;**

Serial numbers:

**2018 - ... (from 1805-...)**

Manufactured by:

**Tapflo AB**

**Filaregatan 4**

**4434 Kungälv, Sweden**

This declaration of conformity is issued under the sole responsibility of the manufacturer.

Object of declaration: **FT filter Units**

The object of the declaration described above is in conformity with the relevant Union harmonization legislation:

- Directive 2006/42/EC of European Parliament and of the Council of 17 May 2006 on machinery, amending Directive 95/16/EC;
- Directive 2014/68/EU of the European Parliament and of the Council of 15 May 2014 on the harmonisation of the laws of the Member States relating to the making available on the market of pressure equipment.

Mr Michał Śmigiel is authorized to compile the technical file.

Tapflo Sp. z o.o.  
ul. Czatkowska 4b  
83-110 Tczew

Signed for and on behalf of  
Tapflo AB



Håkan Ekstrand  
Managing Director

Tapflo AB, 23.05.2018r

# 0. GENERAL

---

## 0. GENERAL

### 0.1. Introduction

FT is a filter unit with a built in Tapflo CTM pump. Manufactured from PP with high finish and mechanical strength. FT filters range meets the demands of today's industries. With proper maintenance FT filters give efficient and trouble-free operation. This manual will familiarize operators with detailed information about installing, operating and maintaining of the filter unit.

### 0.2. Warning symbols

The following warning symbols are present in this instruction manual. This is what they say:



This symbol stands next to all safety instructions in this instruction manual where danger to life and limb may occur. Observe these instructions and proceed with utmost caution in these situations. Inform also other users of all safety instructions. In addition to the instructions in this instruction manual, the general safety and accident prevention regulations must be observed.



This signal stands at points in this instruction manual of particular importance for compliance with regulations and directives, for correct work flow and for the prevention of damage to and destruction of the complete filter or its subassemblies.



This symbol signals possible danger caused by the presence of electric fields or live wires.

# 0. GENERAL

---

## 0.3. Qualification and training of personnel



The personnel in charge of installation, operation and maintenance of the filters we produce must be qualified to carry out the operations described in this manual. Filters can be operated only by qualified staff. Due to possibility of transferring highly aggressive chemicals, safety clothes, shoes, gloves and glasses must be worn. Tapflo shall not be held responsible for the training level of personnel and for the fact that they are not fully aware of the contents of this manual.



# 1. INSTALLATION

---

## 1. INSTALLATION

### 1.1. Receiving inspection



Although precaution is taken by us when packing and shipping, we urge you to carefully check the shipment on receipt. Make sure that all parts and accessories listed on the packing list are accounted for. Immediately report any damage or shortage to the transport company and to us.

In case of emergency, electric motor must be immediately stopped, and the valves must be closed.

### 1.2. Storage



If the equipment is to be stored prior to installation, place it in a clean location. Clean the filter thoroughly before installation.

In case of using FT filter with CTP pump, when in storage, turn the pump shaft by hand at least twice per week.

### 1.3. Foundation



Make sure that the filter unit is standing on a firm, flat and horizontal foundation. Make sure that filter base is placed evenly on the foundation to eliminate risk of tilting and falling off the filter unit. The filter unit will operate properly without being fixed to a foundation. If fixation is needed for an installation, make sure the foundation is proper to be fixed with filter unit.

### 1.4. Environment



- There should be enough space in the vicinity of the filter in order to operate, maintain and repair it.
- The area in which the filter is operated, must be sufficiently ventilated. Excessive temperature, humidity or dirt may affect the filter operation.
- Behind the cooling fan of the motor there must be sufficient room for the hot air to escape the motor.

### 1.5. Suction and discharge piping



A filter unit is part of a piping system that can include a number of components such as valves, fittings, filters, expansion joints, instruments, etc. The way the piping is arranged and the positioning of the components has a great influence on the operation and the lifetime of the filter unit. The filter unit cannot be used as a support for the components connected to it.

# 1. INSTALLATION

---

## 1.5.1. Connection of discharge pipe



Make sure to fit the discharge pipe to the discharge. Shut-off / regulation valve is fitted on the discharge side. The shut-off / regulation valve excludes the pump from the line and adjusts the output. Never adjust flow rate using the valve on the suction pipe. Always close valves slowly to avoid „fluid hammer“ effect.

## 1.5.2. Connection of suction pipe



Make sure to connect the suction pipe to the pump inlet. The suction piping is very important for the correct operation of the filter unit. It must be as short and as direct as possible. If a longer suction line is unavoidable, the diameter should be large enough, i.e. at least the same size as the inlet connection on the pump to ensure less flow resistance. In any case, suction must be carried out properly avoiding any air locks.



The CTM and CTP pumps, which are parts of the filter units, are a single-stage centrifugal type, thus not self-priming. Therefore it is necessary to install a check valve in all cases when the static height of the liquid is lower than the suction height of the pump. The suction piping must be air tight. Air taking is more probable with long suction lines or if suction occurs with negative head. Critical points in these terms are also the seals between flanges and the seals of the valve stems. Even small amount of air in the suction line can cause serious operating problems and the pump stop.

## 1.6. Health and safety

The filter unit must be installed according to local and national safety rules.



**The filters are constructed for particular applications. Do not use the filter on applications different from that for which it was sold without consulting us to ascertain its suitability.**

### 1.6.1. Protection



In the interest of health and safety it is essential to wear protective clothing and safety goggles when operating, and/or working in the vicinity of Tapflo filter units.

### 1.6.2. Electrical safety



Do not carry out any maintenance or/and operation on the filter unit while it is running or before it has been disconnected from the power supply. Avoid any danger caused by electric power (for details see current regulations in force). Check that electrical specifications on the motor nameplate are equivalent to the power supply.

### 1.6.3. Chemical hazard



Whenever the filter unit is to be used for a different liquid, it is essential to clean it beforehand in order to avoid any possible reaction between the two products. Before filter unit disassembly clean it thoroughly.

# 1. INSTALLATION

---

## 1.6.4. Dry running



Do not start nor carry out running tests before filling the pump with liquid. Always avoid dry operation of the pump. Start the pump when it is completely filled and with the valve on the discharge side almost completely closed.

## 1.6.5. Noise level



CTM and CTP pumps, including the motor, in normal operating conditions produce a sound level below 80 dB(A). The major sources of noise are: liquid turbulence in the installation, cavitation or any other abnormal operation that is independent from the filter unit construction nor the filter manufacturer. The user must provide suitable protective means if the sources of noise could produce a harmful noise level for operators and for the environment (in compliance with current local regulations).

## 1.6.6. Temperature hazards



Raised temperature can cause damage on the filter unit and/or piping and may also be hazardous for personnel in the vicinity of the filter unit/piping. The hot or cold parts of the machine must be protected to avoid accidental contacts.

## 1.6.7. Rotating parts



Do not tamper with the protection of the rotating parts, do not touch or approach rotating parts in movement.

## 1.6.8. Powerful magnetic field



Magnetically driven pumps (CTM) use high intensity magnets. All pacemaker carriers must not approach magnetic components; intense magnetic field can disturb heart pace.

## 1.6.9. Explosive environment



Tapflo Filter Units **are not** certified for use in explosive environments. Consult Tapflo for further information. Incorrect installation or use may cause injury or death to personnel in the vicinity of the installation!

## 1.7. Accessories



In order to ensure a proper control of the performance and the conditions of the installed filter unit, we recommend using the following accessories:

- a pressure-vacuum gauge on the suction piping;
- a pressure gauge on the discharge piping.

# 1. INSTALLATION

The pressure intake must be made of straight piece of piping at a distance of minimum five diameters from the pump inlets. The pressure gauge on discharge must always be fitted between the filter unit and the shut-off/ regulation valve.

## 1.7.1. Electric power

The electric power absorbed by the motor can be measured by means of a wattmeter.

## 1.7.2. Optional accessories

The optional accessories (e.g. frequency inverter) can indicate if filter unit is working in an abnormal way. The abnormal conditions can be caused by: accidentally closed valves, lack of pumped liquid, overloads, etc.

## 1.8. Motor connection



An expert electrician must always carry out the electrical connection. Compare the power supply with the data plate specifications and then choose a suitable connection. The type of connection is stated on the motor data plate and can be Y (star) or D (Delta), according to the power supply of the motor (see table below).

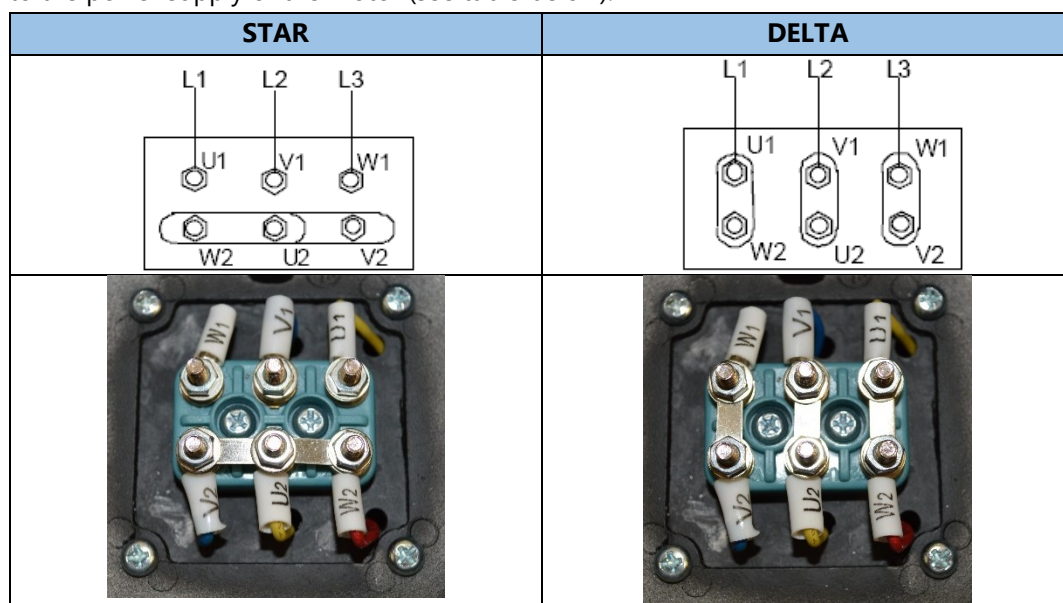

Follow the connection standard used in the plant. In no case connect the electrical motor directly to supply network but use a suitable electric switchboard equipped with a knife switch and suitable safety devices (e.g. motor breaker switches) in the power circuit. Safety devices against overloads must also protect the motors. Make sure that the motor has suitable grounding and that it has been connected properly.

## 2. OPERATION



### 2. OPERATION

#### 2.1. Start-up



- Check manually that the motor is free to turn by moving the motor cooling fan.
- The filter cartridges are delivered wrapped in a foil. Make sure to remove the foil before starting the filter unit. For installation / replacement of the filters see chapter 3. „Maintenance“



- Make sure that the piping is not clogged and is free from residues or foreign objects.
- Make sure that the liquid flows regularly into the pump.
- The pump and piping connected to it, at least the suction pipe, must be full of liquid. Any air or gas must be carefully released. In case of suction with negative head, fill the suction piping and check how the check valve works. It must guarantee that the liquid must not flow back, emptying therefore the suction pipe and eventually disconnection of the pump.



- The suction and discharge shut-off / regulation valves (if any) must be completely open.
- The release valve [52] must be closed.



- The shut-off / regulation valve on the discharge side must be almost completely closed.
- The motor must turn in the same direction as the arrow shown on the pump. The direction of rotation is always clockwise looking at the pump from the motor side; check by starting briefly, then looking at the direction of rotation of the motor fan through the fan lid. If it is wrong, the motor must be stopped immediately. Change the connection to the terminals of the electric motor (chapter 1.8 "Motor connection") and repeat the procedure described above.
- Any auxiliary connections must all be connected.

#### 2.1.1. Starting the unit

- Prime the pump and start the electric motor.
- Open the air vent valve to release air from filter. **Warning:** Liquid may squirt from the vent valve. Connect a hose to direct the flow from the vent valve to a bucket or a tank.
- Close the vent valve when solution level rises to the top of the chamber.
- Check the filter unit for leaks.



**Warning:** Do not open the filter cover while the pump is working!

**Warning:** Do not exceed inner pressure of 2,5 bar!

#### 2.1.2. Restarting after power shut-off

In case of accidental stopping, make sure that the non-return valve has prevented backflow and check that the motor cooling fan has stopped. Start the pump again following the instructions of chapter 2.1.1 "Starting the unit".

## 2. OPERATION



### 2.2. Stopping the unit



To stop the work of the filter unit:

1. Close the discharge and suction valves and stop the pump motor immediately after.

To stop the filter unit and drain medium from filter chamber:

1. Close the discharge and suction valves and stop the pump motor immediately after.
2. Drain the filter using the release valve [52], by means of a hose fixed to the release valve in order to release the medium left inside the filter chamber.

## 3. MAINTENANCE

---

### 3. MAINTENANCE



**Maintenance work on electrical installations must be performed by qualified personnel and only when the power supply has been shutoff. Follow the local and national safety regulations.**

#### 3.1. Inspections

The CTM range pumps have been designed and tested to run for 5000 hours in ideal working conditions. Please note that it is a conservative figure since the actual duty point of your pump can substantially modify this value. Additional factors such as intermittent operation, type of pumped liquid and installation in the plant may affect the life of components that are subject to wear. In any case, Tapflo advises to service pumps every year, even when used in ideal operating conditions.

- Periodically check suction and discharge pressures.
- Inspect the motor according to the instructions from the motor manufacturer.



**For more information on the CTM pump, please see the CTM pump IOM manual.**



The pressure gauge on the filter is used to indicate how contaminated the filter cartridges are. Increase of pressure value indicates higher level of filter contamination. When pressure rises significantly cartridge replacement is necessary. High pressure inside the filter chamber can also be caused by clogged discharge or closed discharge valve. Too high pressure can cause damage of the filter and a risk to personnel. Please assure that discharge valve is open during operation and it isn't blocked.

#### 3.2. Transport



Tapflo FT filters can be transported only by qualified personnel. There are two permitted ways of transport:



- With use of forklift (see picture below)
- With use of crane and the ropes (see picture below)
- 



It is very important to transport the filter in standing position. During the transport, personnel must be cautious and make sure that following points are fulfilled:

**Warning:** Make sure that filter is empty

**Warning:** Check if pump motor is switched off, cables are and valves are closed

**Warning:** Filter cover is closed tightly

## 3. MAINTENANCE

---

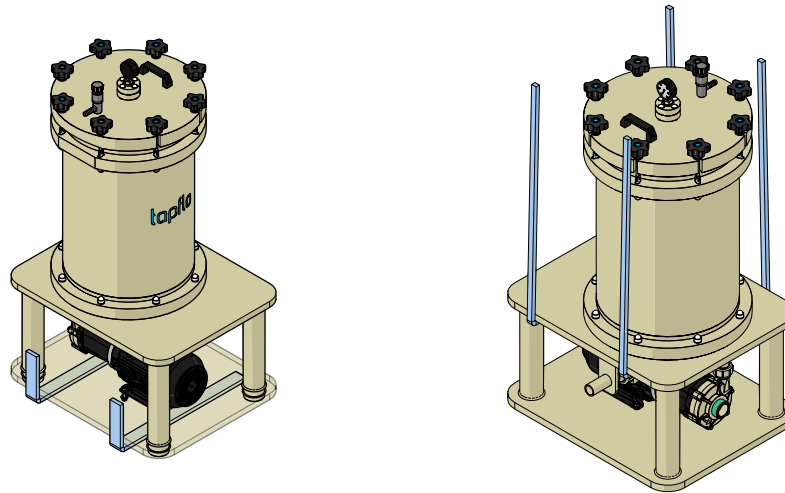

### 3.3. Filter unit disassembly



The disassembly should only be performed by qualified personnel.



Each operation carried out on the machine must always be carried out once all the electrical contacts have been disconnected. The filter unit must be placed in a position where it cannot be started unintentionally.



Before servicing in any way the parts that come in contact with the pumped liquid, make sure that the filter has been fully emptied and washed. When draining the liquid, make sure that there is no danger for people or the environment.

The static and rotating bushings are usually made from very fragile sintered material and therefore have to be handled with extreme care.

The numbers put in brackets, refer to the part numbers in the spare part drawings and spare part lists in chapter 4. "Spare parts".

### 3.4. Filter cover opening



Filter cover can be only opened, when following points are fulfilled:



- Electric motor is switched off
- Air vent valve is opened to release air from filter. **Warning:** Liquid may squirt from the vent valve. Connect a hose to direct the flow from the vent valve to a bucket or a tank.
- Valves are closed



### 3. MAINTENANCE

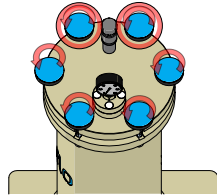

To open filter, stand in front of the filter and untight all of the handles by turning it counter-clockwise

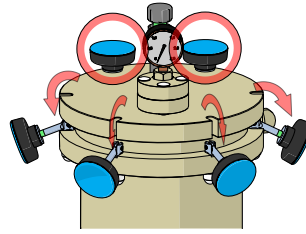

Put off the handles from the filter cover according to the drawing. Make sure that pin screws are laying on the filter collar. Do not put off the screws marked in red circles – these are hinges.

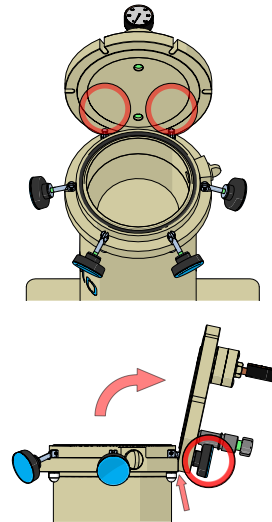

Open the cover. Make sure that cover is laying properly on the trimmed surface – marked with red arrow. This position allows stable and safe work with opened filter.

#### 3.5. Filter cartridge installation / replacement

The procedure is the same for all filter unit sizes: FTA80, FTA160, FTA210, FTA 355.

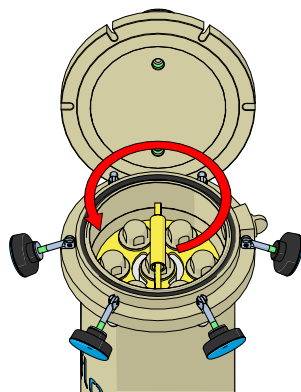

To remove the wound cartridges grab filter handle [yellow], turn it counter-clockwise and then remove from the filter chamber.

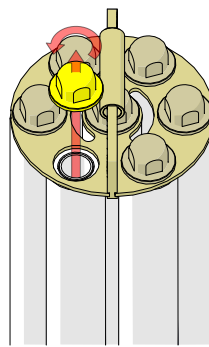

Unscrew the cross pipe nuts counter-clockwise, and then remove filter handle.

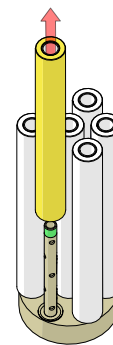

Pull out filter cartridge [90], and replace it with a new one.

**Warning:** a contaminated cartridge can be much heavier than a new one. Always use protective wear during this operation.

### 3. MAINTENANCE

#### 3.6. Filter FTL cartridge installation / replacement

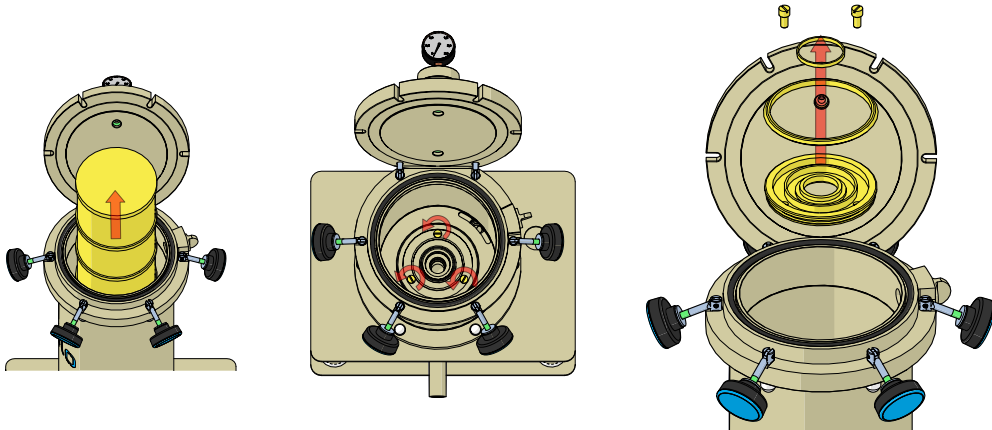

To remove/replace FTL cartridge, simply pull it out from the filter chamber

Unscrew three plastic screws in counter-clockwise direction

Remove FTL disc with sealings. Check if the sealings are in good condition. If yes, put disc and the sealing in the opposite sequence.

#### 3.7. Filter oil absorb installation / replacement

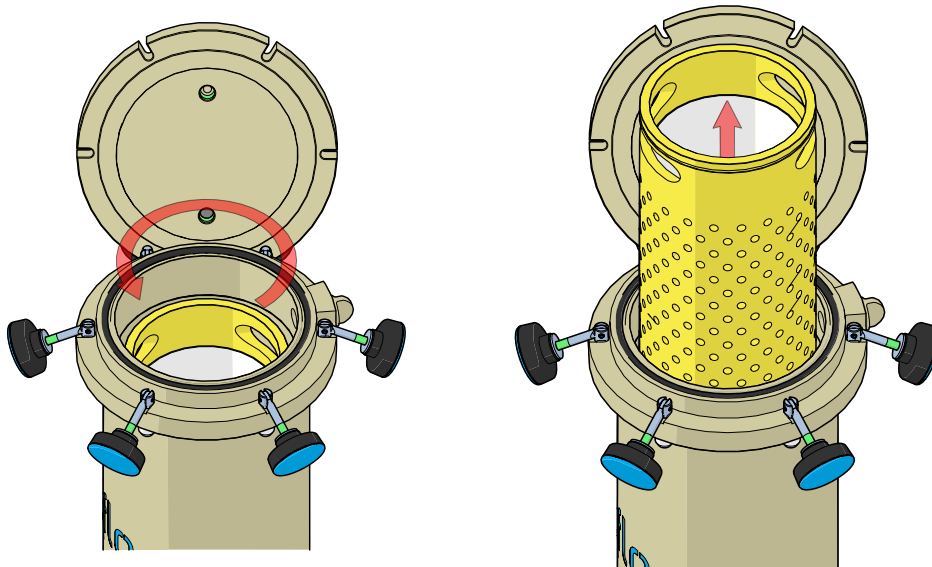

To replace oil absorbing turn the basket counter-clockwise. Make sure, that you wear safety gloves.

Remove basket with oil absorbing fill. Warning – Liquid can be spilled over, do not touch it directly.

#### 3.8. Filter unit assembly

The assembly procedure is done in the reverse order to the disassembly.

## 3. MAINTENANCE

### 3.8.1. Test run



We recommend you to conduct a test run of the pump before installing it in the system, so no liquid gets wasted if the pump leaks or perhaps does not start accordingly to wrong assembly of the pump.

After a few weeks of operation retighten the screws with appropriate torque.

### 3.9. Filter cleaning

To clean the filter chamber remove the base, with cartridge posts that are threaded into the chamber. Removal is not necessary when changing the cartridges. To remove the whole base with posts grab two posts and turn the whole base counter-clockwise. Take out the base.

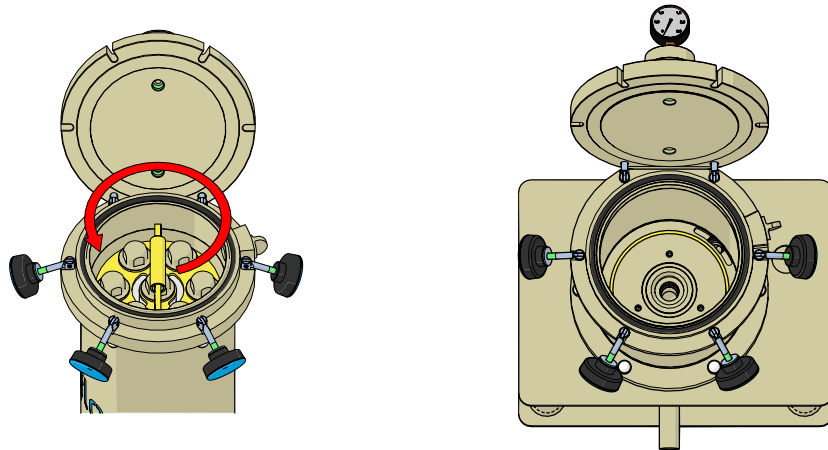

To remove the wound cartridges grab filter handle [yellow], turn it counter-clockwise and then remove from the filter chamber.

Remove the contaminants from the filter chamber. Make sure that filter chamber is clean. Check if o-ring 81 [yellow] is not damaged and placed in the groove correctly

### 3.10. Diaphragm separator calibration

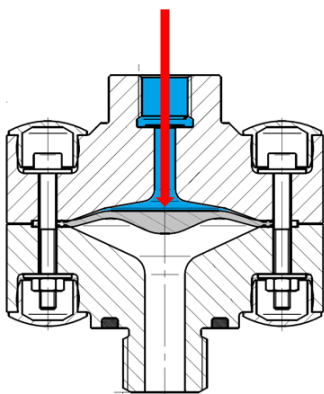

1. Screw the separator [21] into the filter cover [13].
2. Push the separator diaphragm from the top, by means of a screw driver or any blunt long object, to set the diaphragm in end position (red arrow).
3. Fill up the separator with glycerin (blue color) until the end of the thread.
4. Repeat point 2. a few times to release air from any pockets, in order to assure that no air is left in the chamber.
5. Refill glycerin if needed (see point 3.).
6. Place pressure gauge/switch seal on the separator.
7. Screw the pressure gauge/switch into the separator. Excess of glycerin will flow out of the separator.

Required amount of Glycerin – approx.. 20ml.

# 4. SPARE PARTS

## 4. SPARE PARTS

### 4.1. Spare parts – FTA-80

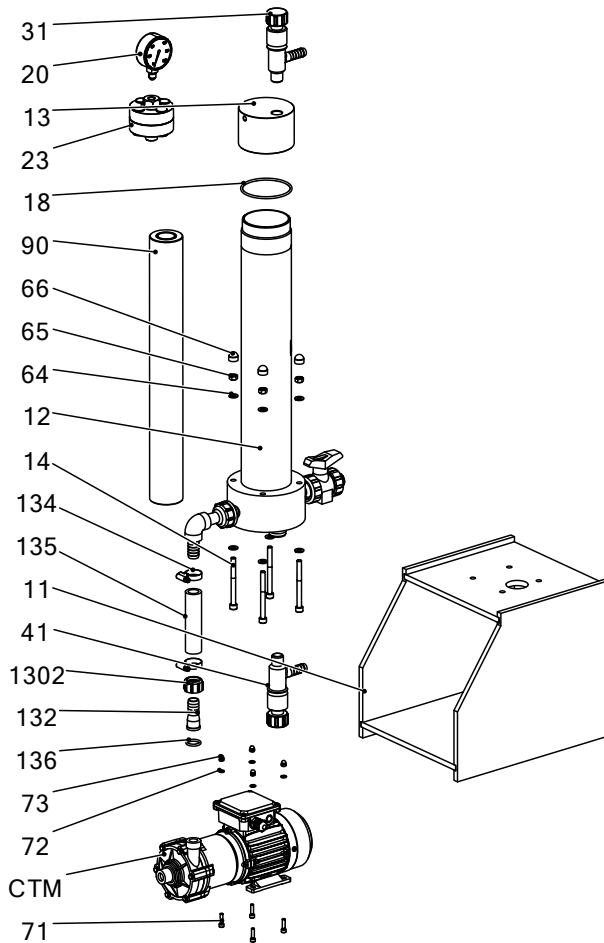

Pos.	Description	Q-ty	Material
11	Pump box	1	PP
12	Filter housing	1	PP
132	Hose connector	1	PP
1302	Hose connector nut	1	PP
134	Hose clamp	2	A4-70
135	Hose	0,1 m	EPDM
136	O-ring	1	EPDM
14	Bolt	4	EPDM
18	Cover o-ring	1	EPDM
20	Pressure gauge	1	PA
23	Diaphragm separator	1	PP
31	Vent valve	1	PVC
41	Release valve	1	PVC
64	Washer – filter housing	8	A4-70
65	Nut – filter housing	8	A4-70
66	Nut cover	4	PE
71	Motor mounting screw	4	A4-70
72	Motor mounting washer	8	A4-70
73	Motor mounting nut	4	A4-70
90	Cartridge	1	PP

# 4. SPARE PARTS

## 4.2. Spare parts – FTA-160

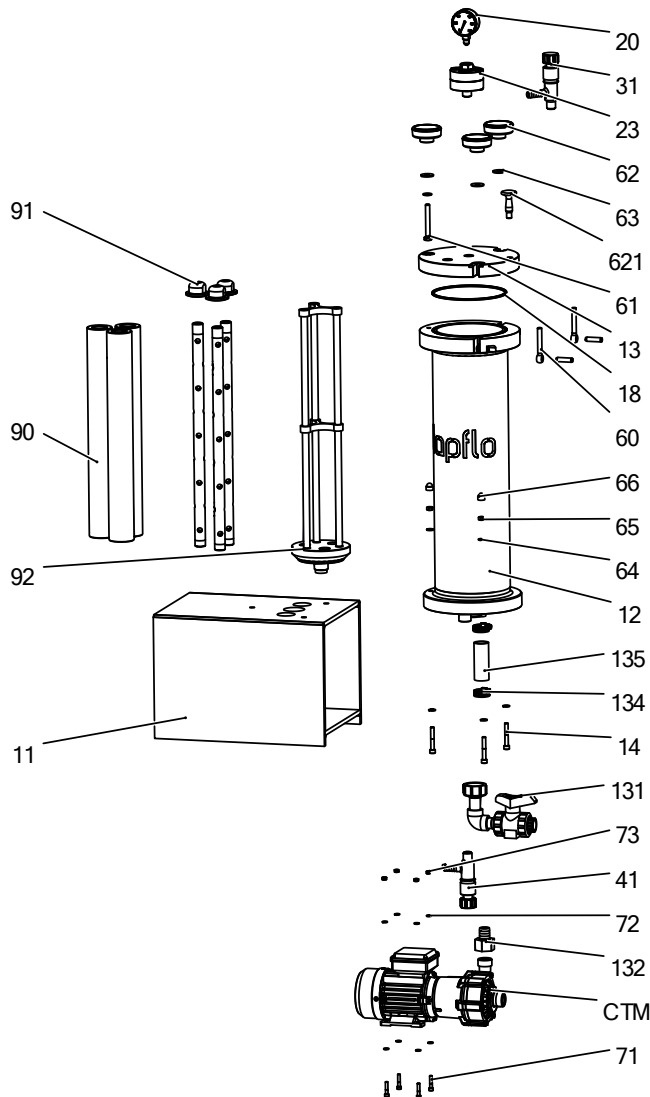

Pos.	Description	Q-ty	Material
11	Pump box	1	PP
12	Housing	1	PP
13	Filter cover	1	PP
131	Ball valve assembly	1	PP
132	Hose connector	1	PP
134	Hose clamp	2	A4-70
135	Hose	1	EPDM
14	Bolt	3	A4-70
18	Cover o-ring	1	EPDM
20	Pressure gauge	1	PA
23	Diaphragm separator	1	PP/PTFE
31	Vent valve	1	PP
41	Release valve	1	PP
60	Eye bolt	2	A4-70
61	Bolt	1	A4-70
62	Hand knob	3	PA
621	Hand knob 2	1	PVC
63	Washer – cover	3	A4-70
64	Washer – filter housing	3	A4-70
65	Nut – filter housing	3	A4-70
66	Nut cover	3	PE
71	Motor mounting screw	4	A4-70
72	Motor mounting washer	8	A4-70
73	Motor mounting nut	4	A4-70
90	Cartridge	3	PP
91	Cartridge nut	3	PP
92	Cross pipe	1	PP

# 4. SPARE PARTS

## 4.3. Spare parts – FT-210

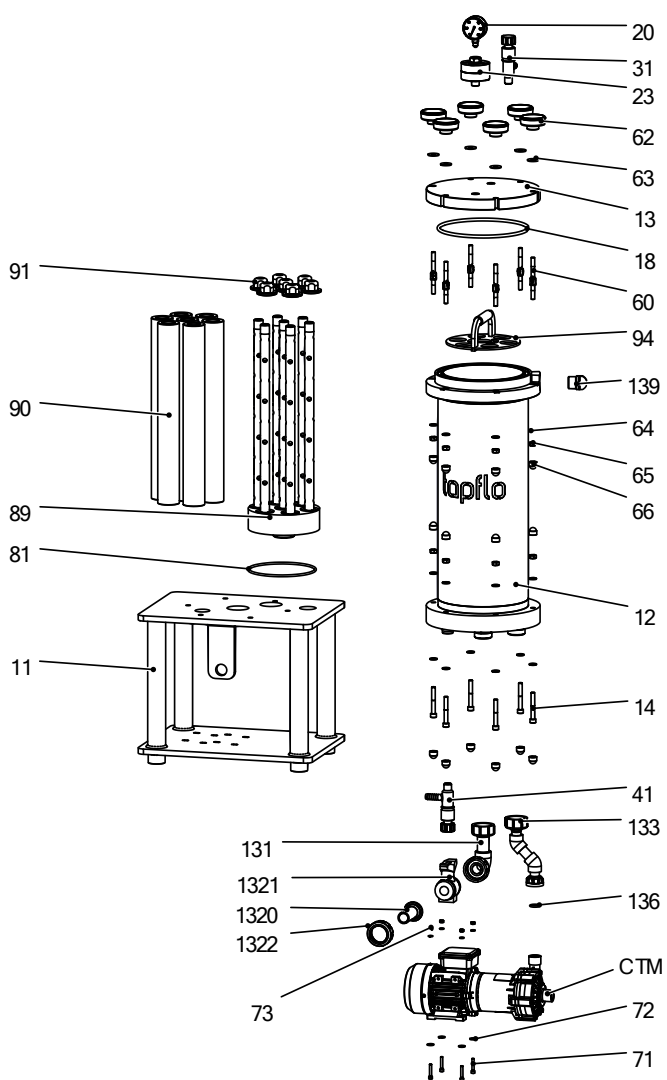

Pos.	Description	Q-ty	Material
11	Pump box	1	PP
12	Housing	1	PP
13	Filter cover	1	PP
131	Ball-valve assembly	1	PP
1320	Hose connector	1	PP
1321	Ball valve	1	PP
1322	Union nut	1	PP
133	Pump-filter connection	1	PP
136	O-ring	1	EPDM
139	Plug	1	PP
14	Bolt	1	-
20	Pressure gauge	1	PA
23	Diaphragm separator	1	PP/PTFE
30	O-ring	2	EPDM
31	Vent valve	1	PVC
41	Release valve	1	PVC
60	Eye bolt	6	A4-70
62	Hand knob	6	PA
63	Washer - cover	12	A4-70
64	Washer – filter housing	18	A4-70
65	Nut – filter housing	12	A4-70
66	Nut cover	18	PE
71	Motor mounting screw	4	A4-70
72	Motor mounting washer	8	A4-70
73	Motor mounting nut	4	A4-70
81	Cartridge o-ring	1	EPDM
89	Wound Cartridge Collector	1	PP
90	Cartridge	7	PP
91	Cross pipe nut	7	PP
CTM	Centrifugal magnetic pump	1	

# 4. SPARE PARTS

## 4.3.1. FTA210 Spare parts – custom inserts

Exploded views below contain additional options for – bag insert, oil absorb insert, carbon insert and ONE cartridge

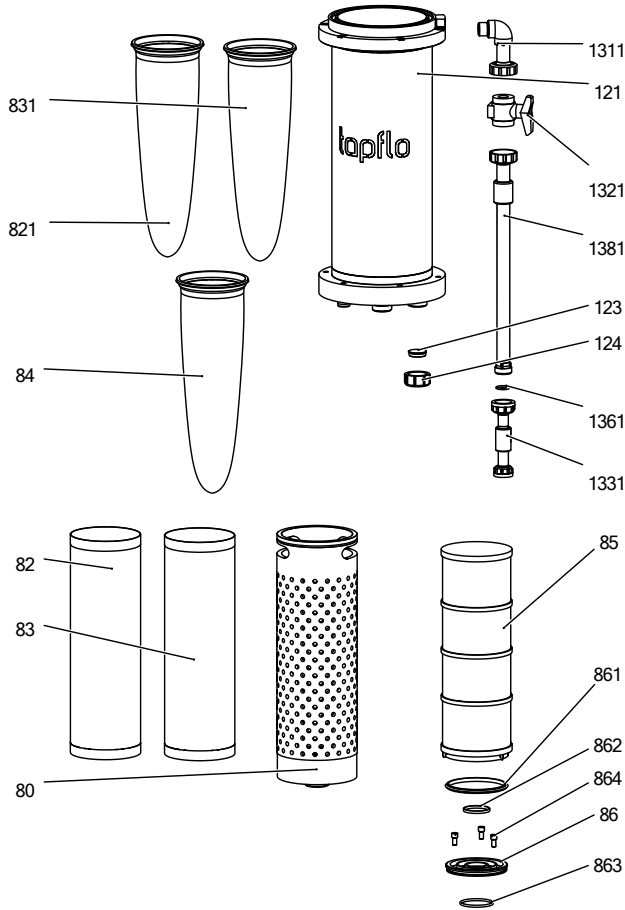

Pos.	Description	Q-ty	Material
121	Housing (FTB)	1	PP
123	End plug	1	PP
124	Nut plug	1	PP
1311	Union nut	1	PP
1321	Valve	1	EPM
1331	Pump connection	1	PP
1361	O-ring	1	EPDM
1381	Pipe connection	1	PP
80	Filtering basket	1	PP
82	Oil absorb insert	1	PP
821	Oil absorb insert (bag)	1	PP
83	Carbon insert	1	PP
831	Carbon insert (bag)	1	PP
84	Bag	1	PP/PE
85	Tapflo FTL Cartridge	1	PP
86	Cartridge base	1	PP
861	V-ring	1	EPDM
862	Cartridge gasket	1	EPDM
863	Cartridge o-ring	1	EPDM
864	Cartridge bolts	3	PP

# 4. SPARE PARTS

## 4.4. FT355 – spare parts

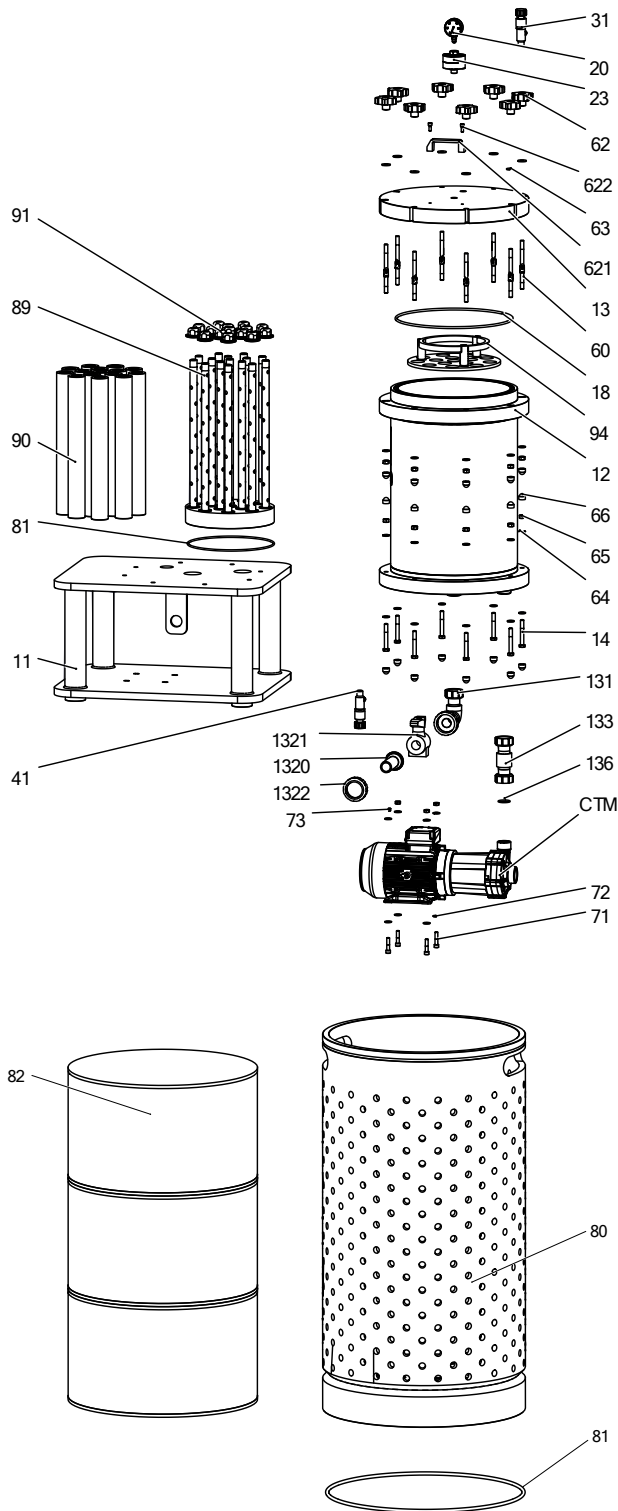

Pos.	Description	Q-ty	Material
11	Pump box	1	PP
12	Housing	1	PP
13	Filter cover	1	PP
131	Ball valve assembly	1	PP
1320	Hose connector	1	PP
1321	Ball valve	1	PP
1322	Union nut	1	PP
133	Pump-filter connection	1	PP
136	O-ring	1	EPDM
14	Bolt	8	A4-70
18	O-ring	1	EPDM
20	Pressure gauge	1	PA
23	Diaphragm separator	1	PP
31	Vent valve	1	PVC
41	Release valve	1	PVC
60	Eye bolt	8	A4-70
621	Handle	1	PP
622	Handle screws	2	A4-70
62	Hand knob	8	PA
63	Washer – cover	8	A4-70
64	Washer – filter housing	24	A4-70
65	Nut	16	A4-70
66	Nut cover	24	PE
71	Motor mounting screw	4	A4-70
72	Motor mounting washer	8	A4-70
73	Motor mounting nut	4	A4-70
80	Filtering basket	1	PP
81	O-ring	1	EPDM
82	Oil absorbing insert	1	PP
83	Activated carbon insert	1	Carbon
89	Wound cartridge collector	1	PP
90	Cartridge	15	PP
91	Cross pipe nut	15	PP

## 4. SPARE PARTS

---



We recommend you to conduct a test run of the pump before installing it in the system, so no liquid gets wasted if the pump leaks or perhaps does not start accordingly to wrong assembly of the pump.

After a few weeks of operation retighten the screws with appropriate torque.

---

### 4.5. Recommended spare parts

Tapflo filter unit with proper maintenance and operation provide easy assembly and trouble free operation. We recommend having filter cartridges on stock:

Pos.	Description	Filter type	Q-ty
90	Filter cartridge	FTA-80	1
90	Filter cartridge	FTA-160	3
90	Filter cartridge	FTA-210	7
90	Filter cartridge	FTA-355	15



**For CTM pump recommended spare parts please see pump IOM manual.**

### 4.6. How to order parts

When ordering spare parts for Tapflo filter units please let us know what is the **model number** and **serial number** from the filter's name plate. Then just indicate the part numbers from the spare parts list and quantity of each item.

# 5. DATA

## 5. DATA

### 5.1. Filter code

The model number on the pump and on the front page of this instruction manual tells the pump size and materials of the pump.

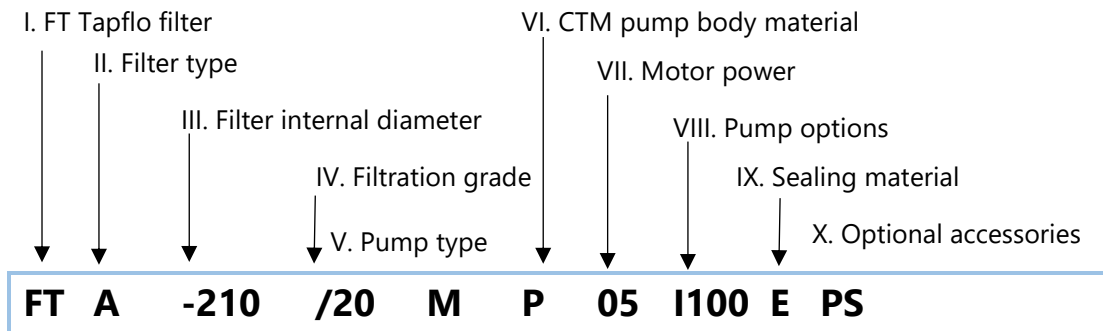

**I. FT = Tapflo filter**

**II. Filter type:**

- A = Cartridge filter
- B = Bag filter
- C = Activated carbon filter
- L = FTL filter
- M = Activated carbon in mesh nylon bag
- N = Oil absorbing fill in nylon bag
- O = oil absorbing fill in bag
- R = ion exchange resin in bag
- S = ion exchange resin in mesh nylon bag

**III. Filter internal diameter [mm]**

**(filter cartridge quantity and dimension):**

- 80 (1x20")
- 160 (3x20")
- 210 (7x20")
- 355 (15x20")

**IV. Filtration grade:**

- 01 = 1 micron
- 10 = 10 micron
- 20 = 20 micron
- 50 = 50 micron

**V. Pump type:**

- M = CTM pump
- P = CTP pump
- V = CTV pump

**VI. Pump body material:**

- P = Polypropylene
- K = PVDF

**VII. Motor power [kW] and CTM pump type:**

- 01 = 0,12 kW (IEC size 56) + CTM20-7 pump
- 02 = 0,25 kW (IEC size 63) + CTM25-8 pump
- 05 = 0,55 kW (IEC size 71) + CTM25-10 pump
- 11 = 1,10 kW (IEC size 80) + CTM32-12,5 pump
- 15 = 1,50 kW (IEC size 90) + CTM40-12,5 pump
- 22 = 2,20 kW (IEC size 90) + CTM40-12,5 pump
- 30 = 3,00 kW (IEC size 90) + CTM50-12,5 pump

**VIII. Pump options:**

- no sign = standard motor
- I = trimmed impeller
- P = single phase motor

**IX. Sealing material:**

- E = EPDM
- F = FKM
- N = NBR

**X. Optional accessories:**

- PS – pressure switch

# 5. DATA

## 5.2. Materials, data and limits

<b>Housing material</b>	PP
<b>O-ring material</b>	EPDM, NBR, Viton
<b>Max temperature</b>	60°C
<b>Max system pressure</b>	2,5 bar

## 5.3. Dimensional drawing – FTA-80

Dimensions in mm (where other is not indicated)

General dimensions only, ask us for detailed drawings. Changes reserved without notice.

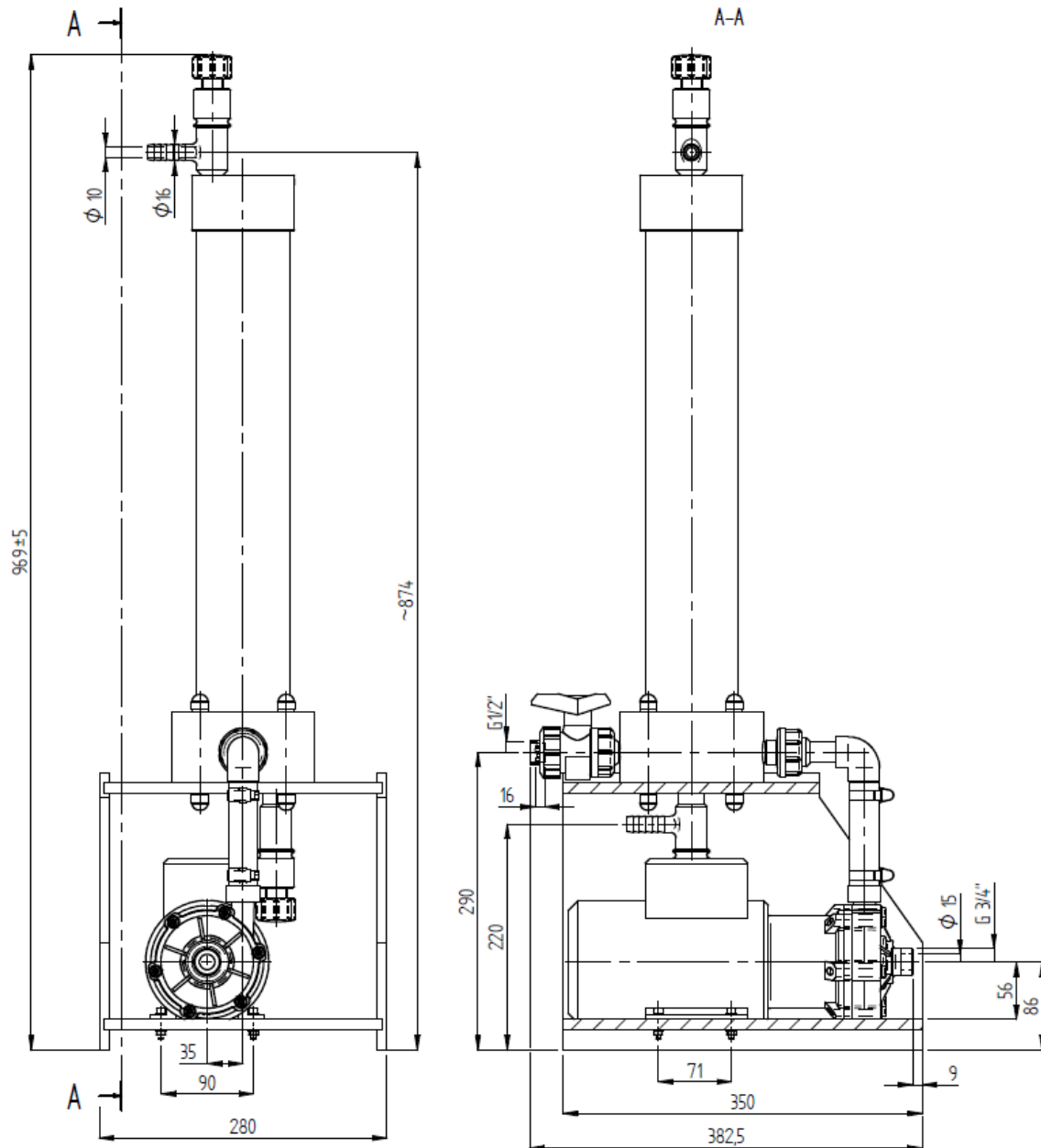

# 5. DATA

## 5.4. Dimensional drawing – FTA-160

Dimensions in mm (where other is not indicated)

General dimensions only, ask us for detailed drawings. Changes reserved without notice.

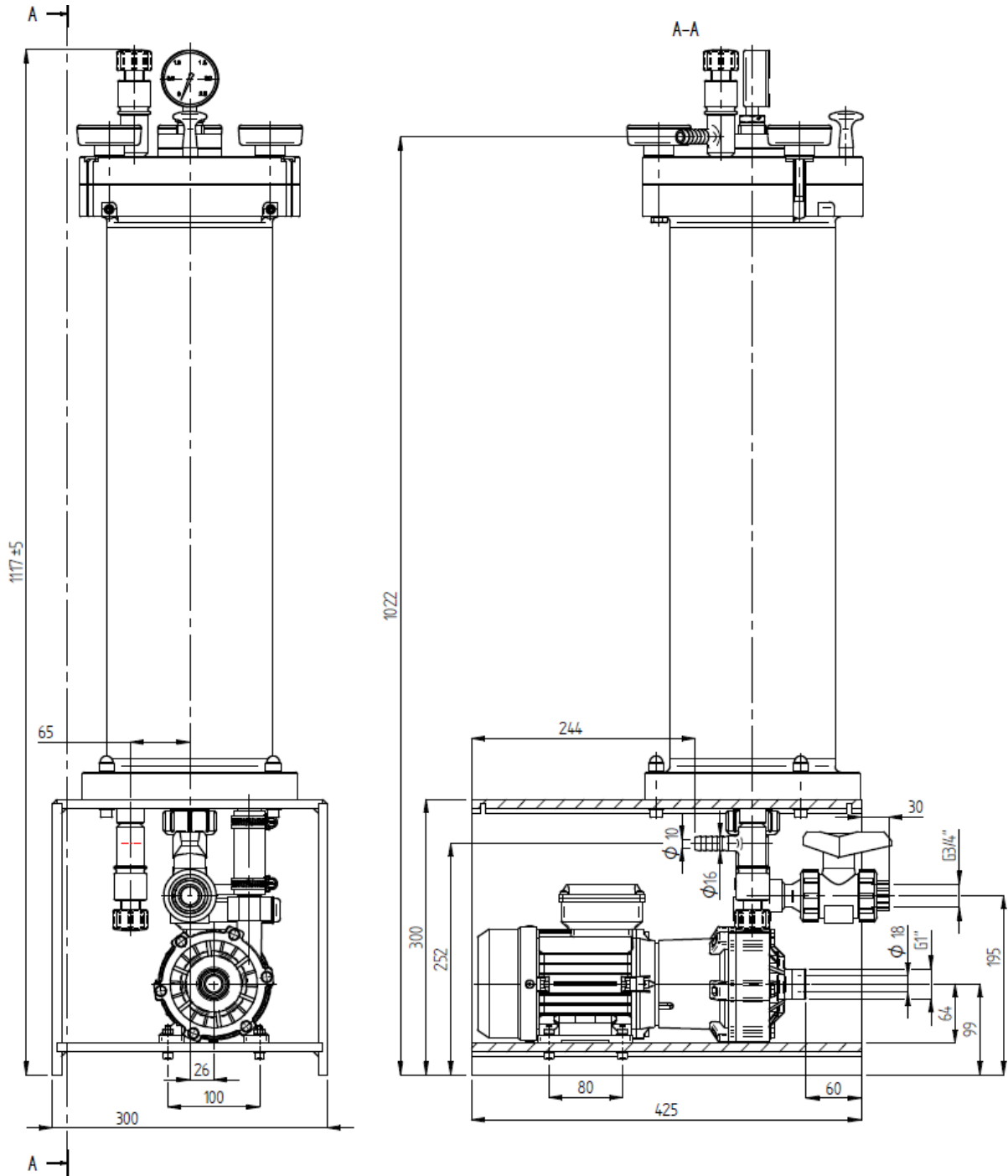

# 5. DATA

## 5.5. Dimensional drawing – FTA-210

Dimensions in mm (where other is not indicated)

General dimensions only, ask us for detailed drawings. Changes reserved without notice.

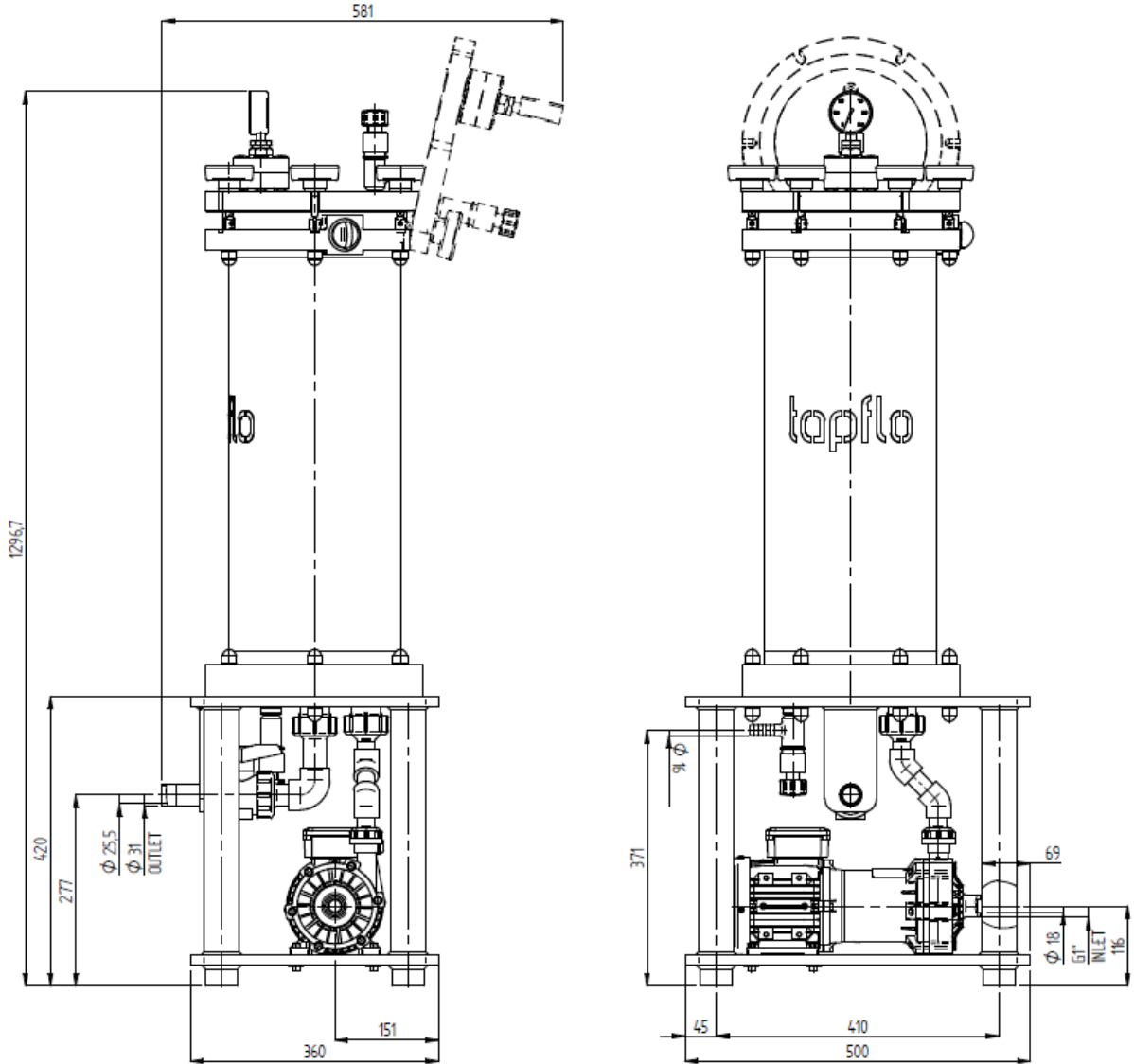

# 5. DATA

## 5.6. Dimensional drawing – FTA-355

Dimensions in mm (where other is not indicated)

General dimensions only, ask us for detailed drawings. Changes reserved without notice.

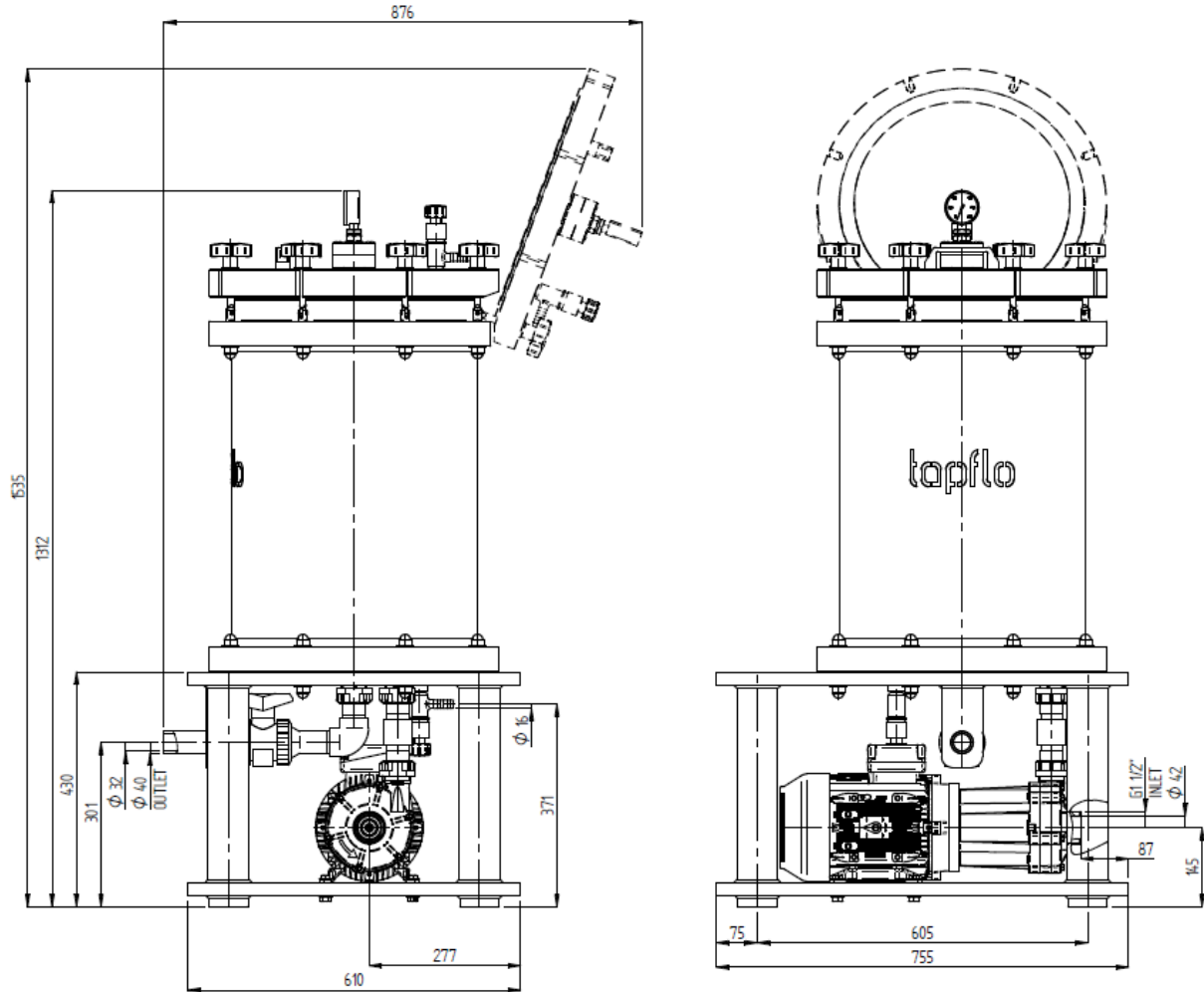

## 6. WARRANTY

---

### 6. WARRANTY

#### 6.1. Returning parts

When returning parts to Tapflo please follow this procedure:

- Consult Tapflo for shipping instructions.
- Cleanse or neutralize and rinse the part/pump. Make sure the part/pump is completely empty from liquid.
- Pack the return articles carefully to prevent any damage during transportation.

***Goods will not be accepted unless the above procedure has been complied with.***

#### 6.2. Warranty

Tapflo warrants products under conditions as stated below for a period of not more than 12 months from installation and not more than 24 months from date of manufacturing.

1. The following terms and conditions apply to the sale of machinery, components and related services and products of Tapflo (hereinafter "the products").
2. Tapflo (the manufacturer) warrants that:
  - a. its products are free of defects in material, design and workmanship at the time of original purchase;
  - b. its products will function in accordance with Tapflo operative manuals; Tapflo does not guarantee that the product will meet the precise needs of the Customer, except for those purposes set out in any invitation to render documents or other documents specifically made available to Tapflo before entering into this agreement;
  - c. high quality materials are used in the construction of the pumps and that machining and assembly are carried out to the highest standards.

Except as expressly stated above, Tapflo makes no warranties, express or implied, concerning the products, including all warranties of fitness for a particular purpose.

3. This warranty shall not be applicable in circumstances other than defects in material, design, and workmanship. In particular warranty shall not cover the following:
  - a. Periodic checks, maintenance, repair and replacement of parts due to normal wear and tear (seals, O-rings, rubber items, bushings, etc.);
  - b. Damage to the product resulting from:
    - b.1. Tampering with, abuse or misuse, including but not limited to failure to use the product for its normal purposes as stated at the time of purchase or in accordance with Tapflo instructions for use and maintenance of the product, or the installation or improper ventilation or use of the product in a manner inconsistent with the technical or safety standard in force;
    - b.2. Repairs performed by non-skilled personnel or use of non-original Tapflo parts;

## 6. WARRANTY

---

- b.3. Accidents or any cause beyond the control of Tapflo. including but not limited to lightning. water. fire. earthquake. and public disturbances. etc.;
4. The warrantee shall cover the replacement or repairing of any parts. which is documented faulty due to construction or assembling. with new or repaired parts free of charges delivered by Tapflo. Parts subjected to normal tear and wear shall not be covered by the warranty. Tapflo shall decide as to whether the defective or faulty part shall be replaced or repaired.
  5. The warrantee of the products shall be valid for a period in accordance to the current law from the date of delivery. under the condition that notice of the alleged defect to the products or parts thereof be given to Tapflo in written within the mandatory term of 8 days from the discovery. Repair or replacement under the terms of this warranty shall not give a right to an extension to. or a new commencement of. the period of warranty.
  6. Repair or replacement under the terms of this warranty shall not give a right to an extension to, or a new commencement of, the period of warranty. Repair or replacement under the terms of this warranty may be fulfilled with functionally equivalent reconditioned units. Tapflo qualified personnel shall be solely entitled to carry out repair or replacement of faulty parts after careful examination of the pump. Replaced faulty parts or components will become the property of Tapflo.
  7. The products are built in accordance with standard CE normative and are tested (where applicable) by Tapflo. Approval and tests by other control authority are for the customer's account. The products shall not be considered defective in materials. design or workmanship if they need to be adapted. changed or adjusted to conform to national or local technical or safety standards in force in any country other than that for which the unit was originally designed and manufactured. This warranty shall not reimburse such adaptations. changes or adjustments. or attempt to do so. whether properly performed or not. nor any damage resulting from them. nor any adaptation. change or adjustments to upgrade the products from their normal purpose as described in the products operative manual without the prior written consent of Tapflo.
  8. Installation. including electric and other connections to utility mains according to Tapflo drawings. is for the cost and responsibility of the customer. unless otherwise agreed in writing.
  9. Tapflo will not be liable on any claim. whether in contract. tort. or otherwise. for any indirect. special. incidental. or consequential damages. caused to the customer or to third parties. including loss of profits. arising by any possible infringement of par. 3 above or by the customer or third parties being in the impossibility of using the products.

# 6. WARRANTY

Steady the above. Tapflo liability to the customer or third parties from any claim, whether in contract, tort, or otherwise, shall be limited to the total amount paid by the customer for the product that caused the damages.

## 6.3. Warranty form

Company: _____	
Telephone: _____	Fax: _____
Address: _____	
Country: _____	Contact Name: _____
E-mail: _____	
Delivery Date: _____	Date of pump installation: _____
Pump type: _____	
Serial No (see name plate): _____	
Description of the fault: _____	
_____	
_____	
<b>The installation:</b>	
Liquid: _____	
Temperature [°C]: _____	Viscosity [cPs]: _____ Spec grav. [kg/m <sup>3</sup> ]: _____ pH-value: _____
Content of particles: _____	% of max size [mm]: _____
Flow [l/min]: _____	Duty [h/day]: _____ No of starts per day: _____
Discharge head [mWC]: _____	Suction head / lift [m]: _____
Other: _____	
_____	
<b>Place for sketch of installation:</b>	

